

# NON-CONTACT SPECTROPHOTOMETER

## OPERATION MANUAL

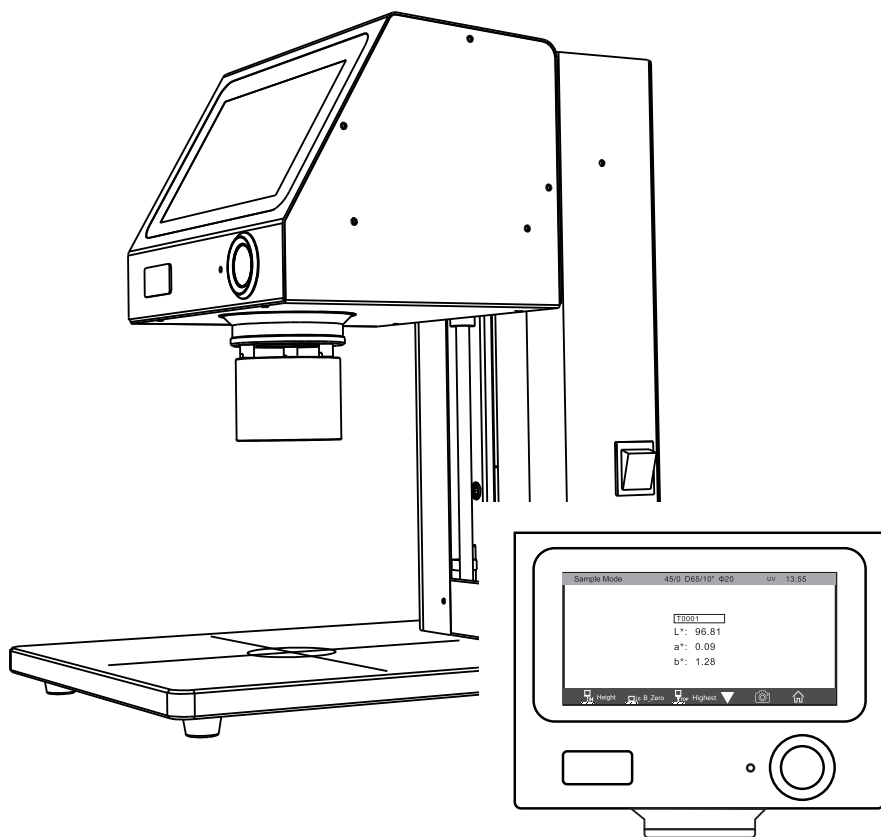

V4.0

# Table of Contents

Overview.....	1
Precautions.....	1
1. Interface Button Description and Measurement Principle.....	2
1.1 Interface Button Description.....	2
1.2 Measurement Principle.....	3
2. Operating Instructions.....	6
2.1 Connecting the Power Supply.....	6
2.2 Black and White Calibration.....	7
2.3 Measurement Interface Description.....	9
2.3.1 Sample Mode Measurement Interface.....	9
2.3.2 Quality Control Mode Measurement Interface.....	10
2.3.3 Continuous Statistics Mode Measurement Interface.....	10
2.4 Measuring.....	11
2.4.1 Sample Mode Measurement Interface.....	12
2.4.2 Quality Control Mode Measurement Interface.....	14
2.4.3 Continuous Statistics Mode Measurement Interface.....	15
2.4.4 Average Measurement Settings.....	16
2.4.5 Continuous Statistics Mode Settings.....	17
2.5 Communication with PC.....	18
2.5.1 Communication with PC via USB.....	18
2.5.2 Communicate with PC via Bluetooth.....	18
2.6 Printer.....	18
3. System Function Description.....	19
3.1 Data Management.....	19
3.1.1 View Records.....	19
3.1.2 Delete Records.....	19
3.1.3 Search Records.....	21
3.1.4 Standard Input.....	22
3.2 Black and White Calibration.....	24
3.3 Height Settings.....	24
3.4 Measure Mode.....	26
3.5 Illuminant/Color Space.....	27
3.5.1 Illuminant Settings.....	27
3.5.2 Illuminant Selection.....	28

# Content

3.5.3 Color Space.....	28
3.6 Color Index.....	29
3.6.1 Set the Color Difference Formula.....	29
3.6.2 Set Optional Chromaticity Index.....	30
3.6.3 Parameter Factor Settings.....	31
3.7 Tolerance Setting.....	33
3.8 System Settings.....	34
3.8.1 Measure Speed.....	36
3.8.2 Bluetooth.....	36
3.8.3 Buzzer.....	36
3.8.4 Print Data.....	36
3.8.5 Language Settings.....	36
3.8.6 Time and Date Settings.....	37
3.8.7 Screen Backlight Time.....	38
3.8.8 Measurement Control Mode.....	38
3.8.9 Screen Brightness.....	39
3.8.10 Temperature Threshold.....	39
3.8.11 Calibration Validity Period.....	40
3.8.12 System Error.....	41
3.8.13 Restore Factory Settings.....	41
3.8.14 About Instrument.....	42
4. Daily Repair and Maintenance of the Instrument.....	42
5. Technical Specifications.....	42
5.1 Features.....	42
5.2 Technical Specifications.....	43
Appendices.....	45
1. Object Color.....	45
2. Color Difference Formula.....	45
3. Normal color difference allowable range .....	46

## Overview

On the one hand, the non-contact spectrophotometer has a fast test speed (up to 200 milliseconds). On the other hand, the test probe and the tested sample are non-contact tests. For the test samples in the assembly line, liquid, paste, sauce, Samples such as powder can be very convenient to achieve non-contact precision color measurement. During the measurement process, the test probe will not touch the sample, which prevents damage to the sample and at the same time avoids cross-contamination.

The 45/0 series online non-contact spectrophotometer adopts the standard 45°circular uniform illumination specified by CIE, and the 0°receiving geometric optical structure. The D/8 series online non-contact spectrophotometer adopts the approximate diffuse reflection specified by CIE Uniform illumination, 8° receiving, including specular reflection light geometric optical structure, used for accurate color analysis and transmission in laboratories and R&D industries; also used for accurate color measurement and color quality control in automated production lines; in cosmetics, fruits and vegetables, food hygiene , Plastic electronics, paint and ink, printing, ceramics and other industries are widely used, fluorescent samples can also be measured. Its unique innovative design can not only provide non-contact measurement solutions directly from the production line, but also ensure stable and high-precision measurement results.

## Precautions

- 1) This instrument is a precision optical measuring instrument, so drastic changes in the external environment of the instrument should be avoided during measurement, such as flickering of ambient light and rapid temperature changes during measurement.
- 2) During the measurement, the instrument should be kept stable, the object to be measured should be placed on the measurement platform, and the measurement aperture should be aligned to avoid movement.
- 3) This instrument is not waterproof, and cannot be used in high humidity environments or in water mist.
- 4) Keep the instrument tidy and avoid liquid, powder or solid foreign objects such as water and dust from entering the integrating sphere and inside the instrument, and avoid impact and collision on the instrument.
- 5) The standard board should be cleaned regularly with a wiping cloth to ensure that the working surface of the whiteboard is clean. The standard board should be stored in a dark, dry and cool environment.
- 6) After the instrument is used, the power supply should be cut off, and the instrument and standard board should be placed in the instrument box and stored in a dry and cool environment.
- 7) The user is not allowed to make any unauthorized changes to this instrument. Any unauthorized changes may affect the accuracy of the instrument, and even damage the instrument irreversibly.
- 8) Before measuring, make sure that the sample height and the input height are correct, and that there are no other items on the platform, and confirm that the whiteboard and blacktrap have been removed after the black and white calibration is completed, otherwise the instrument may be damaged by impact during movement!

# 1. Interface Button Description and Measurement Principle

## 1.1 Interface Button Description

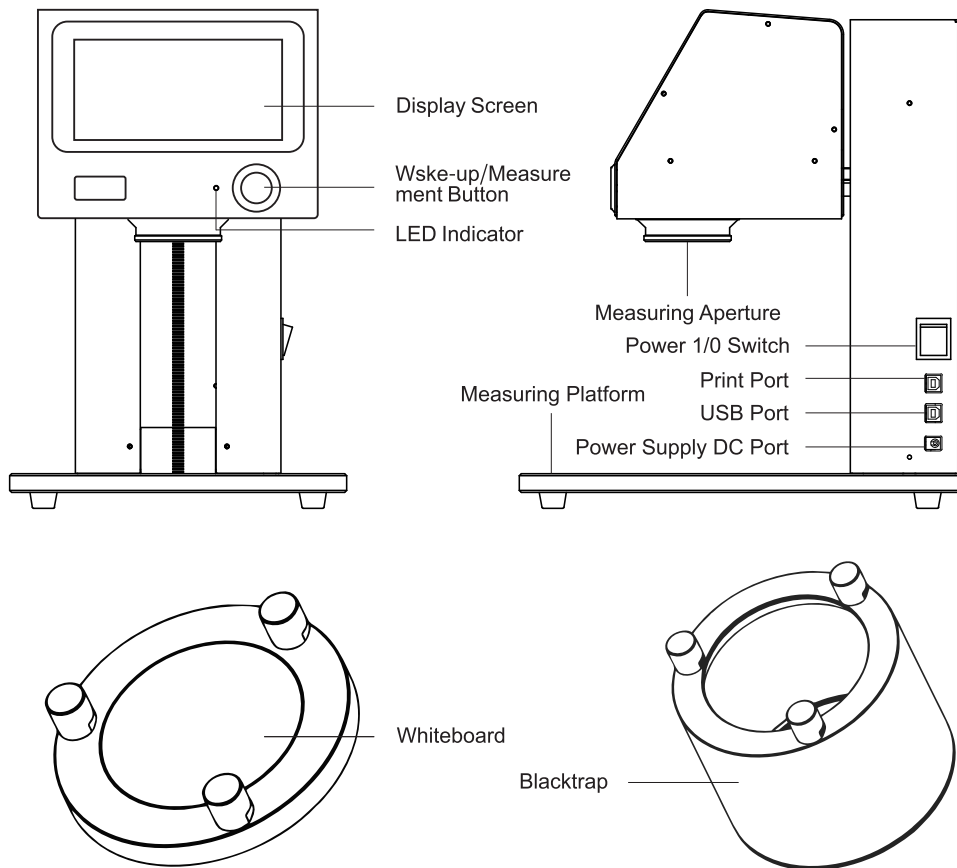

Figure 1 Schematic Diagram of Instrument Button Interface

**Display Screen:** 7-inch TFT pure color capacitive touch screen; used to display measurement data and navigate the instrument operation.

**LED Indicator:** The LED indicator has two indication colors: green and red. When the instrument is powered on (the power adapter is powered on, and the switch is turned to "1"), the indicator light is on. The green light flashes during the measurement, the green light is always on when the measurement is completed, and the red light is always on when the instrument is running abnormally.

**Wake-up/Measurement Button:** Short press the measurement button in standby mode to wake up the system; short press to start measurement, the button operation is invalid during measurement.

**Power 1/0 Switch:** Turn the switch to "1", and the instrument is powered on; when the switch is set to "0", the instrument is powered off and shut down.

**USB Port:** The USB port is used to connect and communicate with a PC, and realize more functional expansion through the computer color management software.

**Print Port:** Used to connect to a printer to print chromaticity data of test samples.

**Power Supply Dc Port:** The instrument is powered by the power adapter. The power adapter inputs AC power (AC 110V-240V), and the output is DC 24V/3A.

**Measuring Aperture:** During black and white calibration, the whiteboard and blacktrap must be close to the measuring aperture. The object to be measured must be placed under the measuring aperture during measurement.

**Measuring Platform:** Used to place the measured object. The measurement platform has a cross positioning, which can make the object to be measured more accurately align the measurement aperture and improve the accuracy of the measurement data.

**Whiteboard:** Used for white calibration in measurement modes, as a benchmark for high reflectance testing of the instrument, please refer to the chapter on black and white calibration for specific operations.

**Blacktrap:** Used for black calibration in measurement modes, as the zero reference of the instrument, please refer to the black and white calibration chapter for specific operations.

## 1.2 Measurement Principle

The picture on the left of Figure 2 is the 45/0 series test principle diagram. According to the 45/0 geometric optical structure specified by CIE15, the light ring uniformly illuminates the surface to be tested (the bottom support plate (fixed) in the figure). The fixed distance of the measuring surface is 7.5mm; use a black tube and a working whiteboard to calibrate the test instrument in black and white, and then place the parts to be tested in the same position.  $\pm 0.2\text{mm}$ ; The instrument collects optical signals separately, and after the dispersion of the optical spectroscopic system, the electronic integrated circuit calculates, and finally presents the chromaticity index of the part to be tested to the display interface.

The picture on the right side of Figure 2 is the D/8 series test principle diagram. According to the CIE15 regulations, the D/8 (including specular reflection light) geometric optical structure, the light is homogenized by the integrating sphere, and the surface to be tested is illuminated by uniform diffuse reflection (the bottom support in the figure) Board (fixed), at this time the fixed distance between the measuring diameter of the instrument and the surface to be measured is 3.0mm; use the working light trap and the working whiteboard to correct the black and white of the measuring instrument, and then place the parts to be measured in the same position, (Note: the measuring diameter of the instrument The distance between the bottom surface and the surface of the working whiteboard and the part to be tested is  $3.0\pm 0.1\text{mm}$ ; the instrument collects optical signals separately, disperses through the optical spectroscopic system, and calculates the

electronic integrated circuit, and finally presents the chromaticity index of the part to be tested to the display interface.

Note: The distance accuracy and parallelism between the test surface of the part to be tested and the plane of the measuring probe have an impact on the test accuracy. Please minimize the error and keep the error within the above range.

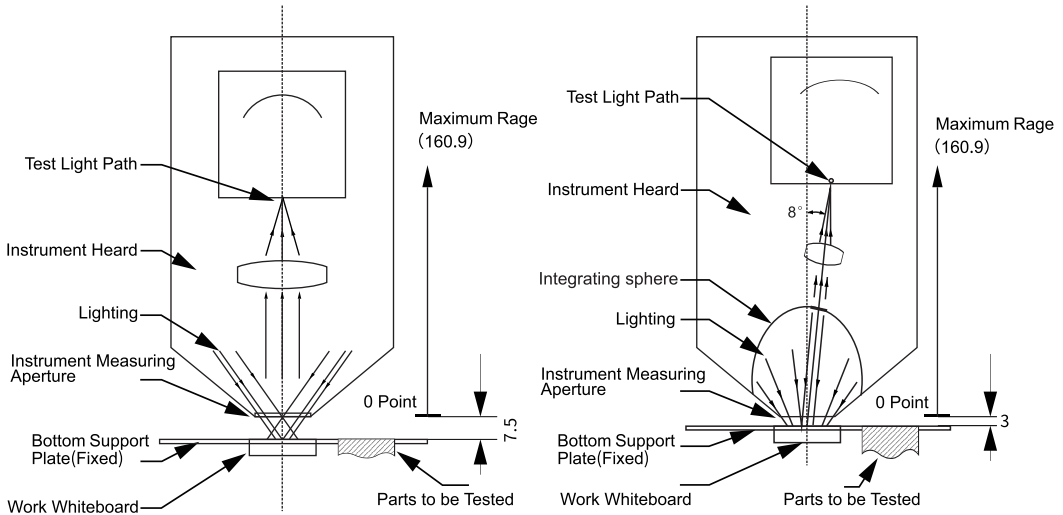

Figure 2 Instrument test principle (45/0 series on the left, D/8 series on the right)

The picture on the left of Figure 3 is a schematic diagram of the 45/0 series test. When testing the test surface of the part to be tested, it is necessary to ensure that the distance between the test surface and the bottom surface of the measurement aperture is  $7.5 \pm 0.2 \text{mm}$ . The common operation method is to place the parts to be tested on the base support plate, input the sample height  $H$  to the instrument, and adjust the head position of the instrument according to the input sample height, so as to ensure that the test surface and the bottom surface of the measuring caliber are  $7.5 \pm 0.2 \text{mm}$ . When the height of the part to be measured is not clear, it is necessary to perform height adjustment on the sample height interface of the instrument.

The picture on the right side of Figure 3 is a schematic diagram of the D/8 series test. When testing the test surface of the part to be tested, it is necessary to ensure that the distance between the test surface and the bottom surface of the measurement aperture is  $3.0 \pm 0.1 \text{mm}$ . The common operation method is to place the parts to be tested on the base support plate, input the sample height  $H$  to the instrument, and adjust the head position of the instrument according to the input

sample height, so as to ensure that the test surface and the bottom surface of the measuring caliber are  $3.0 \pm 0.1 \text{mm}$ . When the height of the part to be measured is not clear, it is necessary to perform height adjustment on the sample height interface of the instrument.

In the actual test process, in order to improve the test efficiency, tooling and jigs can be made to ensure the distance between the test surface of the test part and the measurement caliber (refer to the structure of the working whiteboard and black tube).

**Note:** When the motor drives the head of the instrument to move, avoid hands and objects within the range of the head of the instrument to avoid injury to the body, damage to the object and the instrument.

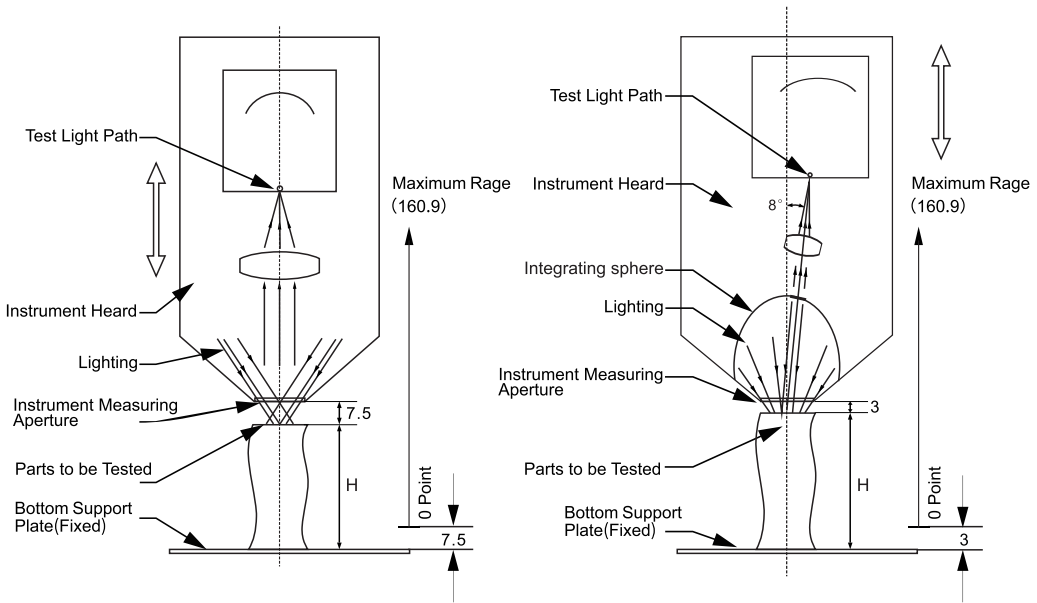

Figure3 Sample height and test diagram (45/0 series on the left, D/8 series on the right)

## 2. Operating Instructions

(In the manual, 45/0 is taken as an example, the D/8 display is slightly different)

### 2.1 Connecting the Power Supply

Turn the power 1/0 switch to "1", the instrument is powered on, and the instrument automatically enters the startup screen, as shown in Figure 4, the instrument starts. Turn the power 1/0 switch to "0", and the instrument will shut down when it is powered off.

If you do not perform any operation for a long time in the power-on state (the power 1/0 switch is turned to "1"), the instrument will automatically enter the sleep state. At this time, press the "Wake-up/Measurement Button" to wake up the instrument and enter the working state. After booting up, directly enter the measurement interface, as shown in Figure 5.

It is recommended to click " Top Highest" in Figure 5 after starting the machine to return the head of the instrument to the highest position, and then perform black and white calibration (ensure that the measuring aperture of the instrument and the bottom support plate have enough space to accommodate the blacktrap and whiteboard).



Figure 4 Instrument Startup Interface

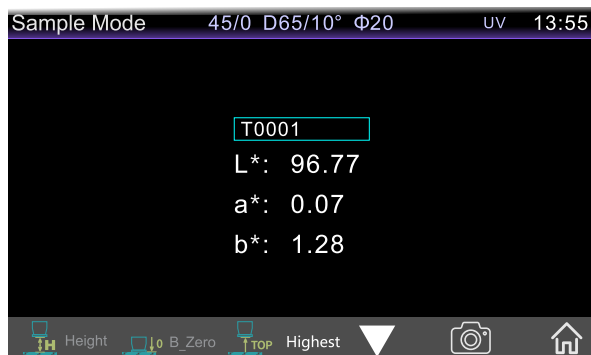





Figure 5 Measurement Interface (Sample Mode)

**Note:** When not using the instrument for a long time, please cut off the power supply.

## 2.2 Black and White Calibration

Before black-and-white calibration, make sure that the measuring aperture of the instrument and the bottom support plate have enough space to accommodate the calibration black tube and calibration whiteboard. In the measurement interface or the height adjustment interface, you can click "  TopHighest " in Figure 5 to return the instrument head to the highest position.

In the measurement interface, press the "Main Menu" area "  "to enter the main menu. In other interfaces, you can enter the main menu by clicking the confirm "  "and return "  "keys at the bottom, as shown in Figure 6.

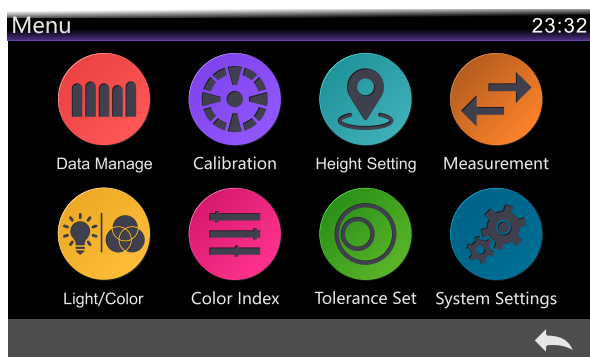

Figure 6 Main Menu

Click "Black and White Calibration" in the main menu to enter the "Black and White Calibration" interface, as shown in Figure 7. The interface will display whether the current calibration is valid and the remaining valid time.

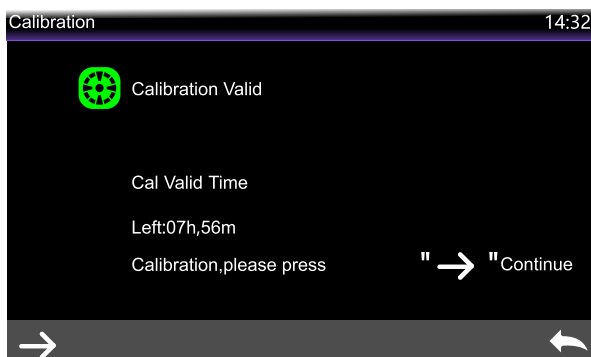

Figure 7 Black and White Calibration

Click " → " to continue the operation and enter the reflectance

Black calibration interface in Figure 8. According to the prompt, attach the blacktrap to the measuring aperture, and then press the measurement button to perform black calibration. Click Back " ← " to cancel calibration as needed.

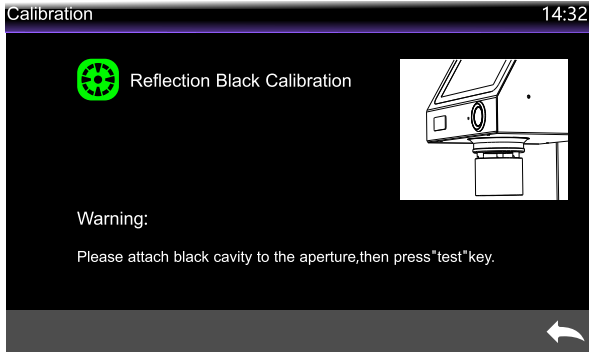

Figure 8 Reflection Black Calibration

After the reflection black calibration is completed, it will enter the reflectance white calibration interface, as shown in Figure 9. Follow the prompts to attach the whiteboard to the measuring aperture, and then press the "Measurement Button" to perform reflectance white calibration. Click Back " ← " to cancel calibration as needed.

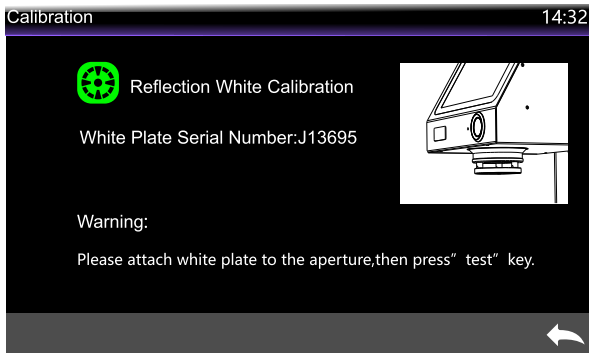

Figure 9 Reflection White Calibration

After the calibration is completed, the instrument system will re-time according to the validity period of the black and white calibration set by the user (as shown in Figure 7). The user can select " → " to continue the calibration according to requirements, or click " ← " to return.

## 2.3 Measurement Interface Description

### 2.3.1 Sample Mode Measurement Interface

When the sample mode is selected as the measurement modes, the instrument system enters the sample mode. The measurement interface is shown in Figures 10 and 11. The upper part of the measurement interface is the working status area. The measurement mode, Bluetooth status, UV and other status of the instrument settings are displayed here in real time. The middle part of the measurement interface is the data display area. The instrument displays the corresponding chromaticity data according to the current user's settings. The bottom of the measurement interface is the operation button area, and the operation of the current data is realized by clicking the corresponding operation button area. Figure 11 shows the spectrum display area. The measurement data interface and the spectrum display interface can be quickly switched by clicking the spectrum graph "▼".

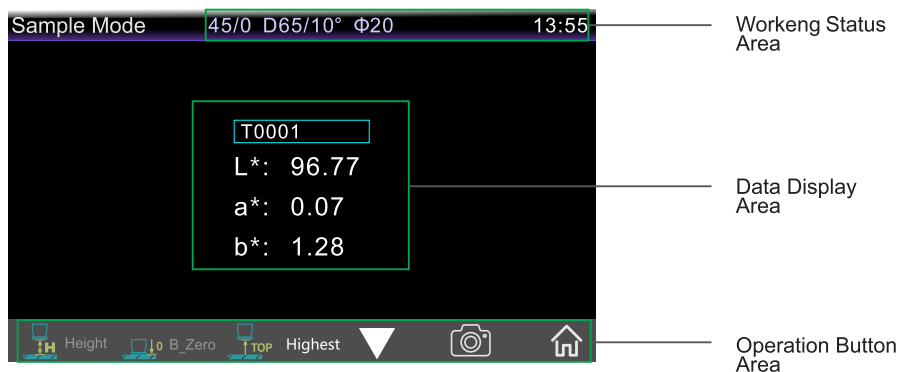

Figure 10 Sample Mode Measurement Interface

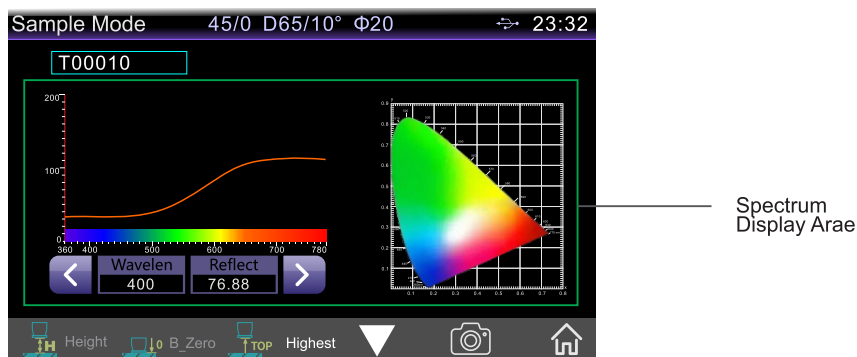

Figure 11 Spectrum Display Interface

### 2.3.2 Quality Control Mode Measurement Interface

When the quality control mode is selected for the measurement modes, the instrument system enters the quality control mode. The measurement interface is shown in Figure 12. The upper part of the measurement interface is the working status area, the middle part of the measurement interface is the data display area, and the bottom of the measurement interface is the operation button area. The operation of the current data is realized by clicking the corresponding operation button area. The difference from the sample mode measurement interface is that one standard sample data and multiple sample data are displayed, which can be scrolled through the buttons on the right. The measurement data interface and the spectrum display interface (the same as the spectrum display interface in sample mode, as shown in Figure 11) can be quickly switched by clicking the spectrum graph “▼”.

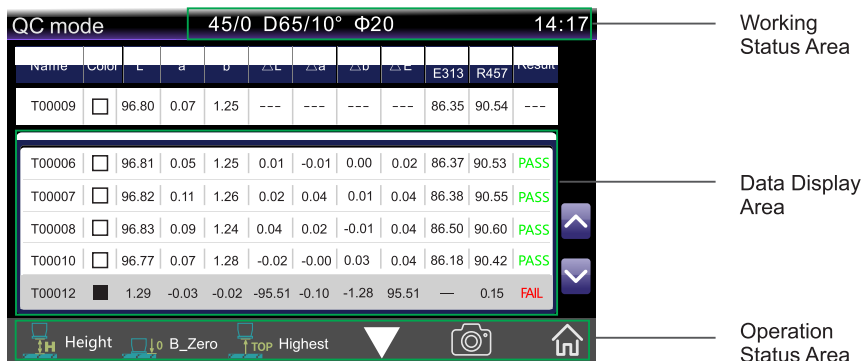

Figure 12 Quality Control Mode Measurement Interface

### 2.3.3 Continuous Statistics Mode Measurement Interface

When the continuous statistics mode is selected for the measurement modes, the instrument system enters the continuous statistics mode. The measurement interface is shown in Figure 13. The upper part of the measurement interface is the working status area. The measurement mode and UV status set by the instrument are displayed here in real time. The left part of the measurement interface is the data display area. The instrument displays the corresponding chromaticity data according to the current user's settings. The right part of the measurement interface is the statistical result display area, which displays the corresponding statistical results. The bottom of the measurement interface is the operation button area, and the operation of the current data is realized by clicking the corresponding operation button. The measurement data interface and the spectrum display interface (the same as the spectrum display interface in sample mode, as shown in Figure 11) can be quickly switched by clicking the spectrum graph “▼”.



Figure 13 Continuous Statistics Mode Measurement Interface

## 2.4 Measuring

Measurement includes sample mode measurement, quality control mode measurement and continuous statistical mode measurement.

**Sample Mode Measurement:** Simple sample measurement, generally used to measure the chromaticity data of the standard.

**Quality Control Mode Measurement:** Generally used to measure the color difference or contrast color data between the sample and the standard. It can be compared intuitively and judged whether it is qualified or unqualified.

**Continuous Statistical Mode Measurement:** For samples with a large measurable area, a single sample can be continuously measured for multiple times, with statistical evaluation function measurement. In this mode, the number of continuous statistical measurements can be set up to 200 times, and the interval time for each measurement can be set. When the measurement button is pressed to start measurement, the instrument will automatically measure according to the set interval time, and stop when the set number of times is reached. If you press the measurement button again during the measurement, you can choose to pause or end the measurement.

**Note:** Regardless of which measurement mode the user uses, the distance between the measuring aperture and the sample to be measured must be adjusted in advance. The distance of the 45/0 series is  $7.5 \pm 0.2\text{mm}$ , and the distance of the D/8 series is  $3.0 \pm 0.1\text{mm}$ .

There are many ways to adjust the measuring aperture and the distance of the measured sample. Here we will explain the most commonly used distance adjustment methods.

Assuming that the user uses the support plate configured by the instrument as the reference (that is, the tested sample is placed on the support plate for testing), click " TOP Highest" on any measurement interface to enter the height settings interface as shown in the figure below. First use a caliper or ruler to accurately measure the height H of the sample to be tested, and then enter the height H into the "Input Height" box in the figure below, and then click "GO". The measuring caliber of the instrument will accurately move to the specified height position. If the input height of the sample to be tested is accurate enough, then the measuring caliber of the instrument and the height of the sample to be tested have reached an accuracy of  $7.5 \pm 0.2\text{mm}$  ( $3.0 \pm 0.1\text{mm}$  for D/8 series). Click the measurement button to perform data measurement; if inputting the height of the tested sample is not accurate enough. You can adjust the distance between the measuring caliber and the tested sample by using a standard plug with 7.5mm (3mm for D/8 series) and

clicking the 5mm/1mm/0.5mm/0.1mm fine-tuning button. It is  $7.5 \pm 0.2\text{mm}$  ( $3.0 \pm 0.1\text{mm}$  for D/8 series), and then measure.

In the process of adjusting the height of the measuring aperture, the distance between the measuring aperture and the support plate is displayed in the "Current Height" box in real time. When the height of the sample to be tested is adjusted accurately and the height will be used repeatedly, it is recommended to click the "Save Button" in the figure below to save the height of the sample. Next time you test the sample of this height, the height can be called directly. As shown in Figure 14.

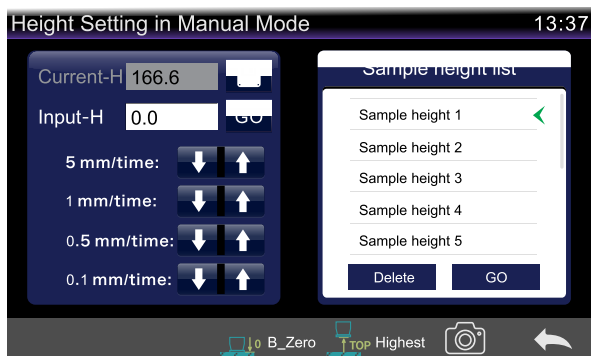

Figure 14 Sample Height Setting in Manual Mode

After the black-and-white calibration is completed correctly, the instrument can be measured after it runs to the specified height.

Place the sample to be tested with reference to the cross positioning line at the center of the measurement platform, and you can also use the built-in camera to adjust the position of the sample accurately. Then the customer sets the corresponding color space and color index in the main menu interface according to their needs (see Chapter 3 for details). The system default color space is CIE lab, the color difference formula is  $\Delta E^*_{ab}$ , and the color index is empty). If you are not currently in the measurement interface, you can continuously click the return " ← " on the interface several times to return to the measurement interface.

### 2.4.1 Sample Mode Measurement Interface

In the sample mode measurement interface, after the sample to be tested has been placed properly, and the correct sample height has been entered (the sample height has been measured with a ruler such as a vernier caliper), gently press the measurement button, and the buzzer will beep. At the same time, the LED indicator flashes until it stops, which means the measurement is completed. The interface of the tested sample after the measurement is completed is shown in Figure 15 and Figure 15-1. The following is a detailed description of the sample mode measurement interface.

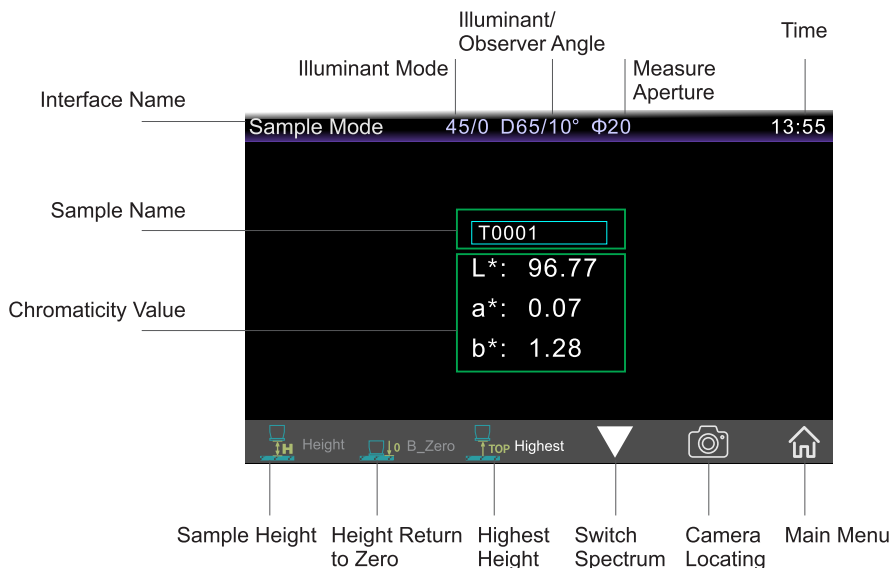

Figure 15 Sample Mode Measurement

- 1) **Interface Title:** Indicates that it is currently in sample mode.
- 2) **Status Bar:** Display system settings information, such as illuminant/observer angle, UV logo, Bluetooth logo, and current date and time. If you choose to turn on Bluetooth, turn on the UV light, the status bar will display the UV logo and Bluetooth logo, otherwise it will not be displayed.
- 3) **Standard Name:** Display the name of the currently tested sample, click to quickly modify it, and the default is the serial number name starting with T0000.
- 4) **Chromaticity Data:** Display the chromaticity data of the currently measured sample.
- 5) **Sample Height:** Click the sample height to enter the sample height settings interface, and re-edit the height value of the sample to be tested, provided that you first click the highest to reset position.
- 6) **Height Back to Zero:** Click height back to zero, the instrument will immediately back to the set height zero position, that is, 0 in the schematic diagram of the measurement principle, provided that you first click the highest position to reset.
- 7) **Highest Height:** Click the highest height, the instrument will immediately back to the highest height set.
- 8) **Spectrogram:** Click this shortcut button to quickly switch the current data between the data display area and the spectrum display area.
- 9) **Camera Locating:** Click the camera icon to use the camera locating function to locate the measurement position. After locating is completed, press the measurement button to complete the measurement.
- 10) **Wavelength Switching Button:** Click the “◀ ▶” button as shown in Figure 15-1, and the optical wavelength and reflectance of the current test sample will be switched at a frequency of 10nm.

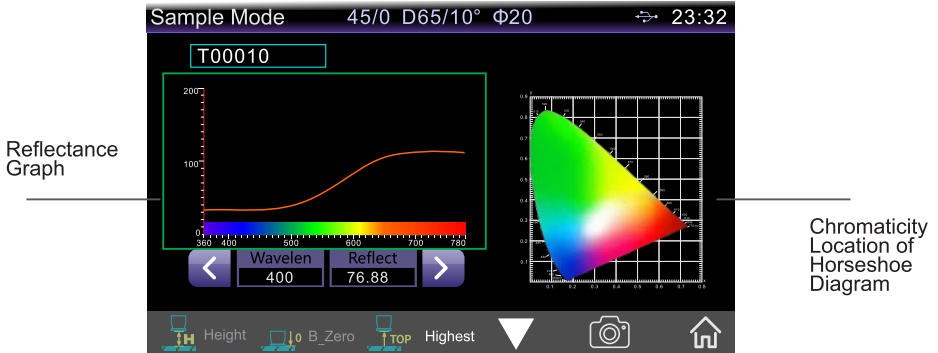

Figure 15-1 Sample Measurement Spectrum Display Interface

### 2.4.2 Quality Control Mode Measurement Interface

In the quality control mode measurement interface, after the sample to be tested has been placed properly and the correct sample height has been entered, gently press the measurement button, the buzzer will beep, and the LED indicator will flash until it stops, which means the measurement is completed. The interface of the tested sample after the test is completed is shown in Figure 16. The following is a detailed description of the parts that are different from the sample mode measurement interface.

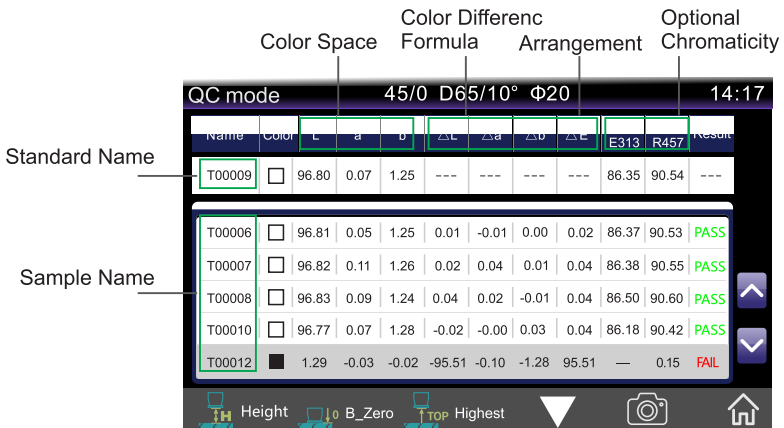

Figure 16 Quality Control Mode Measurement

- Interface Title:** Indicate that it is currently in quality control mode.
- Test Result Prompt:** According to the tolerance setting of the instrument system, compare the measured sample data with the standard sample data. If the measurement result is within the tolerance range, it is judged as pass, otherwise it is fail.
- Standard Name:** Display the name currently used as standard, click to quickly modify it, the default is the serial number name starting with T0000.

4) **Sample Name:** Display the name of the current tested sample, click to quickly modify it, the default name is followed by the serial number of the standard name.

5) The set color space, color difference formula and chromaticity index are listed in fixed positions.

6) **Arrangement Function:** After the  $\Delta E^*$  color difference formula is selected, the arrangement function is supported. Other color difference formulas are temporarily not supported and will be supported after subsequent upgrades.

### 2.4.3 Continuous Statistics Mode Measurement Interface

In the continuous statistical mode measurement interface, after the sample to be tested has been placed properly and the correct sample height has been entered, gently press the measurement button, the buzzer will beep, and the LED indicator will flash until it stops, which means the measurement is completed. The interface of the tested sample is shown in Figure 17 after the test is completed. The following describes the standard interface in detail.

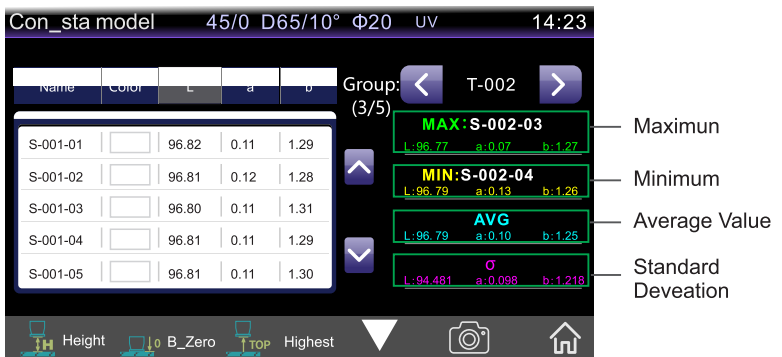

Figure 17 Continuous Statistical Mode Measurement

- 1) **Interface Title:** Indicates that it is currently in continuous statistics mode.
- 2) **Group Name:** Indicates the serial number of a complete statistical record of the current measurement.
- 3) **MAX (Maximum Value):** respectively count the color difference  $\Delta E^*$  maximum value between the average Lab of a complete statistical record and the current Lab within the current set continuous measurement times.
- 4) **MIN (Minimum Value):** respectively count the color difference  $\Delta E^*$  minimum value between the average Lab of a complete statistical record and the current Lab within the current set continuous measurement times.
- 5) **AVG (Average Value):** respectively count the average value of a complete statistical record L, the average value of a and the average value of b within the current set continuous measurement times.
- 6)  **$\sigma$ (Standard Deviation):** is the arithmetic square root of variance. Standard deviation can reflect the degree of dispersion of a data set. Two sets of data with the same average may not have the same standard deviation. A larger standard deviation means that the difference between most of the values and its average is larger; a smaller standard deviation means that these values are closer to the average.

- 7) The left and right arrows can view the data in one group and the next group. The (3/4) under the group name means that the current group is the second group, and there are 2 measurement data in it. By default, a group of data stores 100 data, the maximum is 300 groups in total.
- 8) The up and down arrows can view the data members in the data group.
- 9) Click the group name to display the new group, delete the group, rename the group and other pop-up boxes (Figure 17-1), and you can operate the group.
- 10) Click the color space shortcut button to call up the color space page.

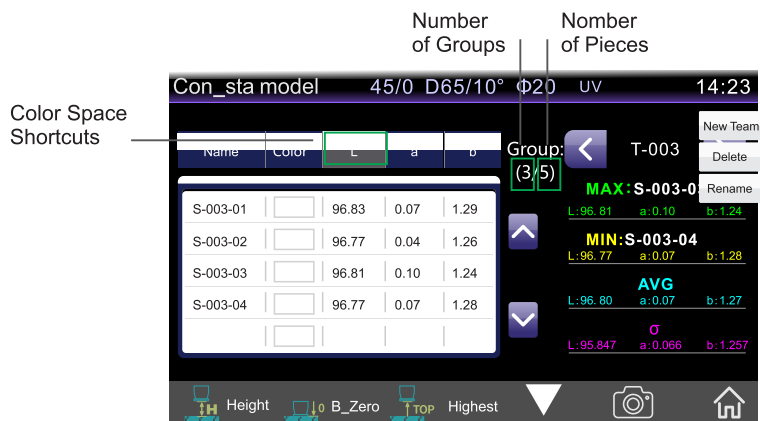

Figure 17-1 Group Test Setting Method

### 2.4.4 Average Measurement Settings

When the tested sample is large or relatively not very uniform, the multi-point average reflectance can be obtained by measuring multiple representative test points, and then the calculated chromaticity data can better represent the true chromaticity value of the tested sample. The instrument can achieve 1-10 average measurements.

Both sample mode and quality control mode can be set for average measurement.

After selecting the mode in the "Modes Selection", enter the "Mode Setting" to enter the average measurement setting interface.

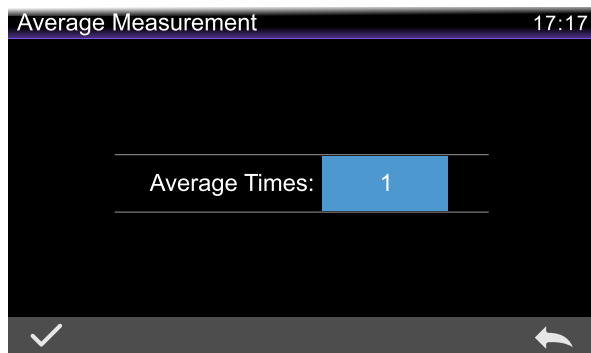

Figure 18 Average Measurement Times Setting

Click the value box, enter the number of average measurements, and click OK.

If the number of average entered is 1, the measurement will be performed in the usual way; if it is greater than 1, the average value of the measurement results will be generated after the specified number of measurements during the standard measurement.

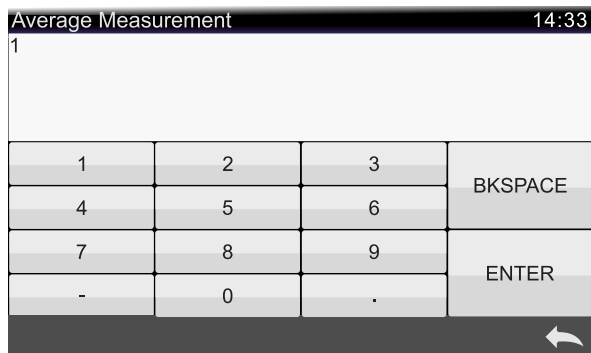

Figure 19 Enter the Number of Measurements for Average Measurement

## 2.4.5 Continuous Statistics Mode Settings

When there are many samples to be tested, the "Continuous Statistical Mode" can be selected for measurement. After selecting the continuous statistical mode in the "Modes Selection", enter the "Mode Setting", that is, enter the continuous statistical mode setting interface, you can set two modes of "Manual Continuous" and "Automatic Continuous". The "Manual Continuous" measurement can be performed manually and continuously for multiple times, each measuring 1 data; the "Automatic Continuous" measurement can realize the continuous measurement interval of 1 to 60 seconds, and the number of continuous measurements is 0 to 9999, as shown in Figure 20.

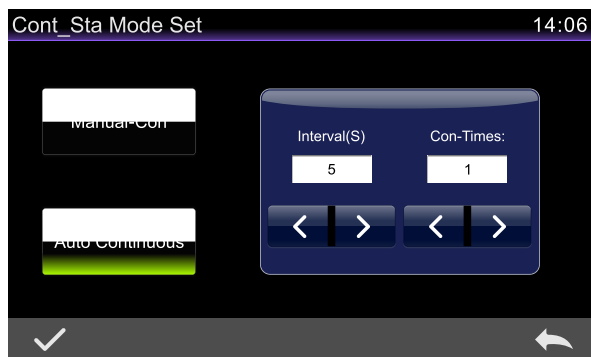

Figure 20 Continuous Statistics Mode Setting

## 2.5 Communication with PC

The PC software has powerful function extensions, which can realize more chromaticity data analysis. This series of instruments can communicate with PC software through USB data cable and Bluetooth module (only for product models equipped with Bluetooth module).

### 2.5.1 Communication with PC via USB

Install the color management software on the PC and connect the instrument to the PC with a USB data cable. The software will automatically connect with the instrument. If the connection is successful, the USB connection icon will be displayed in the status bar of the instrument. Through the color management software, the overall control of the terminal instrument is realized, and the relevant sample measurement and analysis are performed.

### 2.5.2 Communicate with PC via Bluetooth

For instruments equipped with a Bluetooth module, it can communicate with PC color management software through Bluetooth.

Install the color management software on the PC and use the matching Bluetooth adapter. At the same time, turn on the Bluetooth function in the "System Settings" of the instrument. The status bar of the instrument will display the Bluetooth icon, and the software will automatically connect with the instrument. The connection is successful. Realize the overall control of the terminal instrument, and perform relevant sample measurement and analysis.

**Note:** Some instruments have not yet opened the Bluetooth function.

## 2.6 Printer

Micro printers are non-standard accessories and need to be purchased separately. The user can first measure the chromaticity data of the sample, save the sample record to be printed, connect the micro-printer to the instrument via USB, find the sample to be printed in the standard record or sample record, and click "Print Data". As shown in Figure 21.

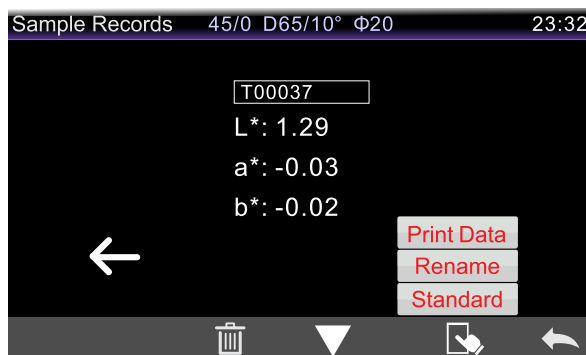



Figure 21 Print Data

### 3. System Function Description

In the measurement interface, press the "Main Menu" area “  ” to enter the main menu. In other interfaces, you can click the return button “  ” to enter the main menu. From the main menu, you can enter each sub-menu to realize all system function settings.

#### 3.1 Data Management

Click "Data Management" in the main menu interface to enter the data management interface, as shown in Figure 22. Data management mainly realizes the viewing and operation of the measured records.

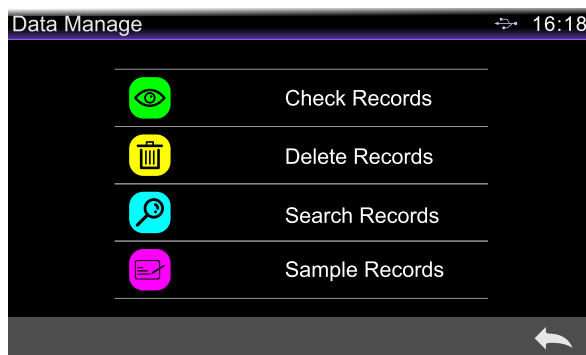

Figure 22 Data Management Interface

##### 3.1.1 View Records

Click "View Records" in the data management interface to enter the "View Records" interface, as shown in Figure 23. View records include: view sample records, view quality control records and view continuous statistical records.

Click "Sample Records" and select "Standard Import, Rename" in the pop-up menu. The instrument will import and rename the current record in the current mode, as shown in Figure 23-1.

##### 3.1.2 Delete Records

Click "Delete Records" in the data management interface to enter the delete records menu interface, as shown in Figure 24. Delete records include "All Samples/Quality Control Records Deleted", "All Continuous Statistical Records Deleted" and "All Records Deleted".



Figure 23 View records

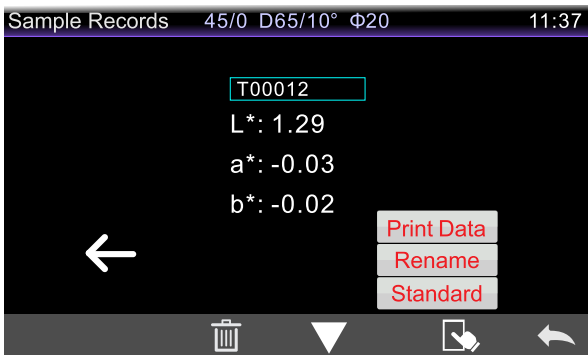

Figure 23-1 Standard Import

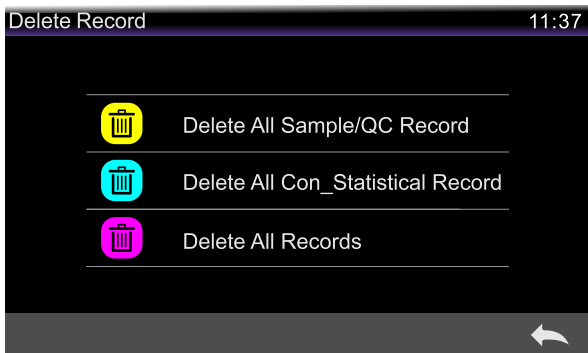

Figure 24 Delete Records Menu Interface

Click the corresponding option to enter the delete prompt warning interface first, click OK“ ✓ ”on the warning interface to delete all corresponding records; if you want to cancel, click Back“ ← ”, as shown in Figure 25.



Figure 25 Warning Interface for all Records Deleted

### 3.1.3 Search Records

Click "Search Records" in the data management interface to enter the search menu, as shown in Figure 26. Search records can choose "Standard/Quality Control Search" and "Continuous Statistical Search".

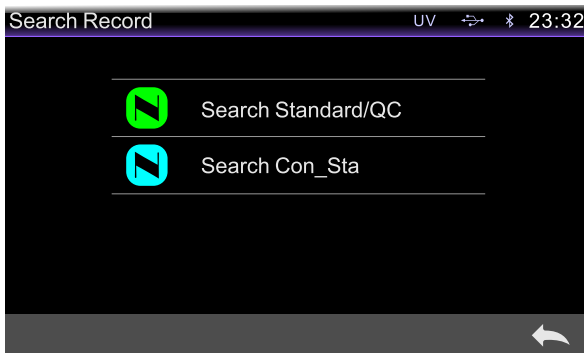

Figure 26 Search Menu Interface

#### 1)Standard/Quality Control Search

Click "Standard e/Quality Control Search" to pop up the search name interface, as shown in Figure 27. Enter the name of the standard/quality control records to be searched or the characters contained in the name, and then click OK. The instrument will automatically perform a search in the standard records and list the standard records that meet the conditions. If there is no matching record, it will prompt "This record does not exist" and return to the search records menu (as shown in Figure 28).



Figure 27 Input Search Name Window

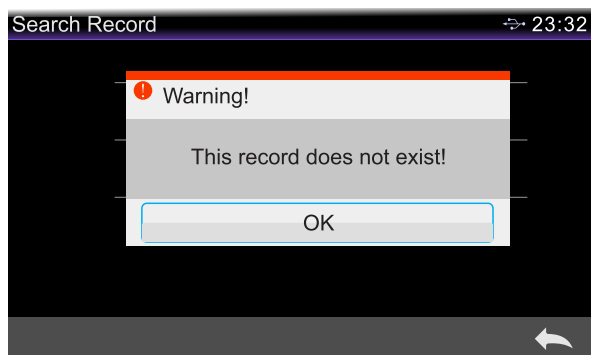

Figure 28 Cannot Find Record Prompt

## 2)Continuous Statistical Search

Click "Continuous Statistic Search" and enter the continuous statistic record to be searched in the input search serial number window. The instrument will automatically perform a search in all continuous statistical records and list the standard records that meet the conditions.

### 3.1.4 Standard Input

Click "Standard Input" in the data management interface to enter the standard input interface, as shown in Figure 29.

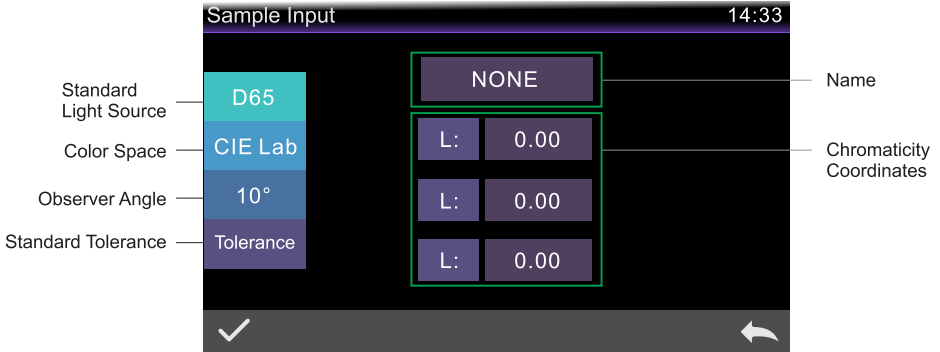

Figure 29 Standard Input

Click the name to enter the name of the standard.

Click the standard light source to set the standard light source of the standard.

Click the color space and select the input color space. Currently, it only supports the input of color values in two color spaces, CIE Lab and CIE XYZ.

Click the observer angle to set the observer angle of the standard.

Click the corresponding chromaticity coordinate and input the chromaticity value under the corresponding coordinate, as shown in Figure 29-1. Click the L coordinate, and the input L window will be displayed. Enter the corresponding L value and confirm.

After inputting all the information of the standard, click " ✓ " to confirm, the standard will be stored in the standard records list, and its standard serial number will be accumulated in sequence.

Note: Manual input of standard on the instrument does not support reflectance input. The input data is only valid under the current observer angle, current measurement mode and current light source. In the viewing standard record interface, if the observer's angle, test mode, and light source changed, the corresponding chromaticity data will be displayed as "- -".

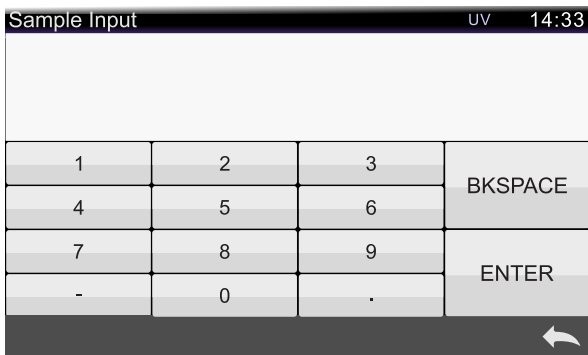

Figure 29-1 Enter the Coordinates of L

### 3.2 Black and White Calibration

Black and white board calibration is used as the benchmark for chromaticity data measurement and must be performed accurately, otherwise it will affect the validity of the test data.

When the black and white board calibration environment is quite different from the current sample test environment (such as severe temperature fluctuations), it is necessary to perform the black and white board calibration on the instrument in time at an interval of 24 hours. It is also recommended to do the black and white board calibration again when testing the samples.

The black and white board should be cleaned on the working surface regularly and kept properly in the dark, dust-proof and dry conditions.

For the black and white board calibration method, please refer to section 2.2.

### 3.3 Height Settings

The height is set in automatic mode and manual mode, as shown in Figure 30. Different models have different modes.

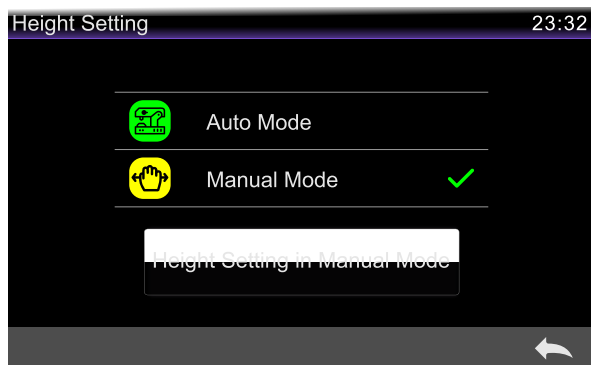



Figure 30 Height Settings



Figure 31 Manual Mode Settings

Click the manual mode settings to enter the manual mode settings interface, which can be edited according to user needs, as shown in Figure 31.

The current height text box is not editable, only the current real-time height is allowed to be displayed. When the height changes, you can click“  ” to store the current sample height for subsequent recall and editing operations.

Click the "Input Height" text box to enter the manual input interface,as shown in Figure 32,and the user manually input the sample height according to the actual sample height. After the sample height value input is confirmed, click“ GO ”to make the motor execute to the corresponding height. If the motor is executed downward, a prompt box will appear, if the motor is executed upward, there will be no prompt, as shown in Figure 33.

Click the“  ”and“  ” after a single adjustment of 5mm to fine-tune with a gradient of 5mm;

Click the“  ”and“  ” after a single adjustment of 1mm to fine-tune with a gradient of 1mm;

Click the“  ”and“  ” after a single adjustment of 0.5mm to fine-tune with a gradient of 0.5mm;

Click the“  ”and“  ” after a single adjustment of 0.1mm to fine-tune with a gradient of 0.1mm;

The sample height storage list lists the sample height records saved from the current height, and can display the latest 5 records. Select a certain sample height record to execute functions such as deleting and entering the corresponding height.

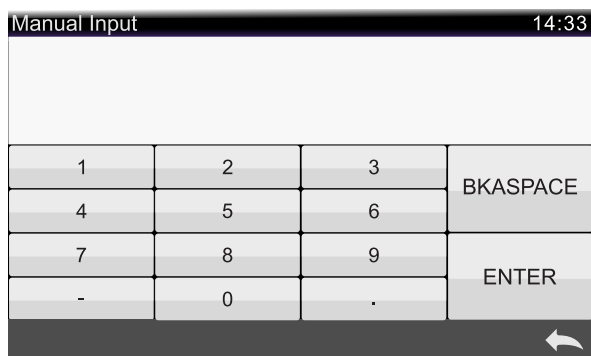

Figure 32 Manual Input of Sample Height

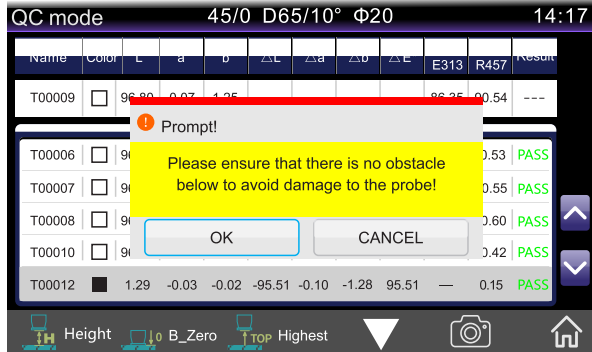

Figure 33 Input Execution Prompt Box

### 3.4 Measure Mode

The measure mode of the non-contact benchtop spectrophotometer include: sample mode, quality control mode and continuous statistical mode.

Click "Measure Mode" in the main menu to enter the measurement modes setting interface, as shown in Figure 34.

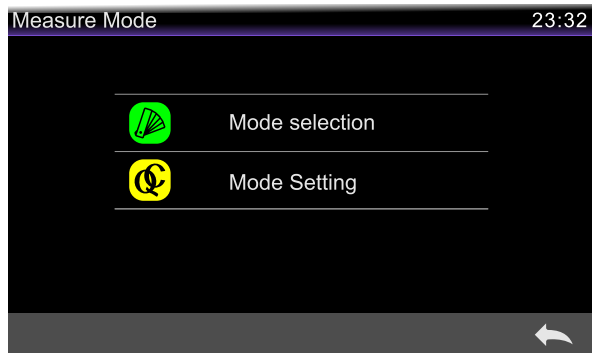

Figure 34 Measure Mode

Enter "Mode Selection", you can select the mode that the user needs to set up the instrument for measurement. As shown in Figure 35.

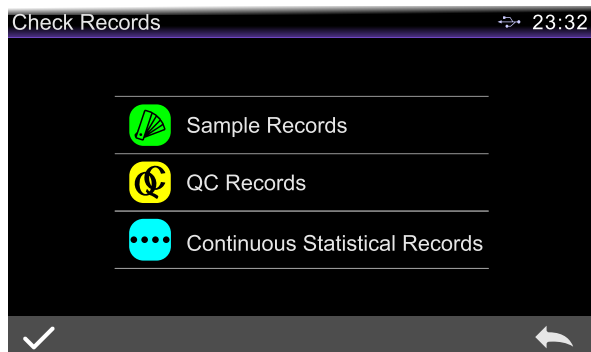

Figure 35 Mode Selection

After selecting the mode, you can set the parameters of the currently selected mode. The sample mode and quality control mode can set the number of average measurements, and the continuous statistics mode can set the number of continuous measurements and the interval time. For the measurement mode and measurement setting method, please refer to section 2.4.

### 3.5 Illuminant/Color Space

Click "Illuminant/Color Space" in the main menu, the user sets the corresponding light source and color space according to the actual test conditions, as shown in Figure 36.

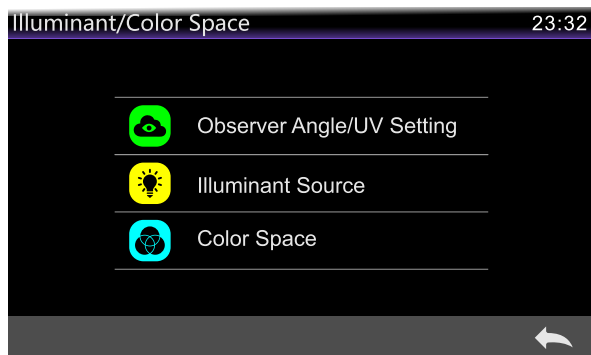

Figure 36 Illuminant/Color Space

#### 3.5.1 Illuminant Settings

In the illuminant settings interface, you can set the system's standard observer angle and UV light source (different instrument configurations are different).

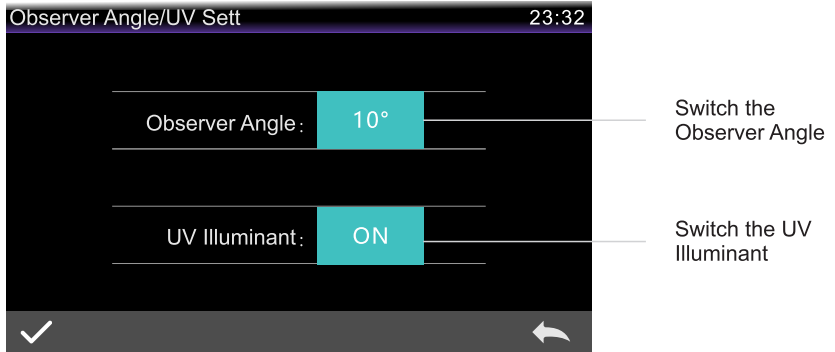

Figure 37 Illuminant Settings

Click the observer angle to switch between 10° and 2°. 10° is the CIE1964 standard and 2° is the CIE1931 standard.

Click the UV light source to switch the UV light source mode.

### 3.5.2 Illuminant Selection

Click "Light Source Selection", as shown in Figure 38, in the light source selection window you can select D65, A, C, D50, D55, D75, F1, F2 (CWF), F3, F4, F5, F6, F7 (DLF), F8, F9, F10 (TPL5), F11 (TL84), F12 (TL83/U30).

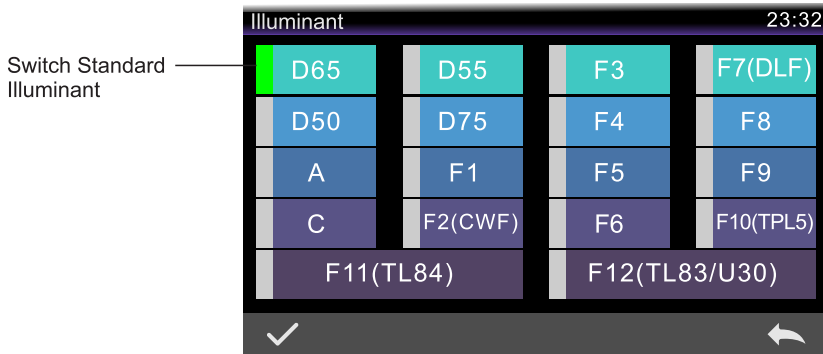
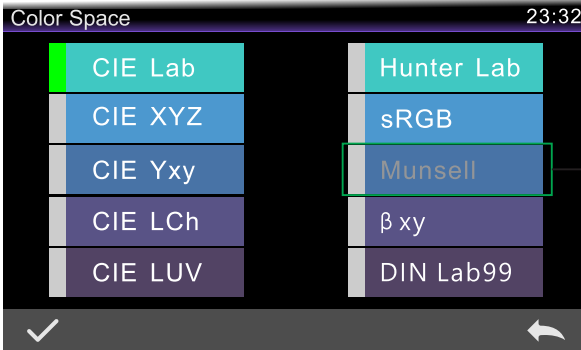

Figure 38 Illuminant Selection Window

### 3.5.3 Color Space

Click "Color Space" to enter the color space interface, as shown in Figure 39, select the corresponding color space in the color space interface, and then click OK" ✓ "to complete the color space setting.



At present, the sample mode and quality control mode have this function, and the continuous statistics mode has a large amount of data calculation, so this function is temporarily not available.

Figure 39 Color Space Interface

### 3.6 Color Index

In the color index interface, the currently used color difference formula and optional chromaticity index can be selected, and the parameter factor of the color difference formula and metamerism index can be set, as shown in Figure 40.

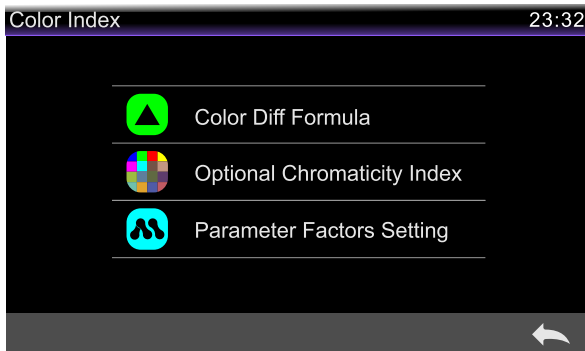

Figure 40 Color Index Interface

#### 3.6.1 Set the Color Difference Formula

In the color index interface, click the "Color Difference Formula" radio column to enter the color difference formula selection interface.

Click on a color difference formula to select the corresponding color difference formula. After selecting the color difference formula, click "✓" to confirm.

Click the color difference formula to select the corresponding color difference formula. The left side of the selected color difference formula will be displayed in green.

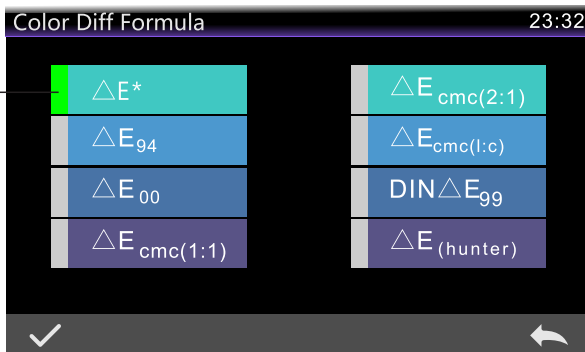

Figure 41 Color Difference Formula Window

The selected color difference formula will be used to calculate the color difference of the sample when the sample is measured. For example, if  $\Delta E^*$  is selected below, the corresponding value will be displayed. Other color differences can be deduced by analogy, as shown in Figure 42.

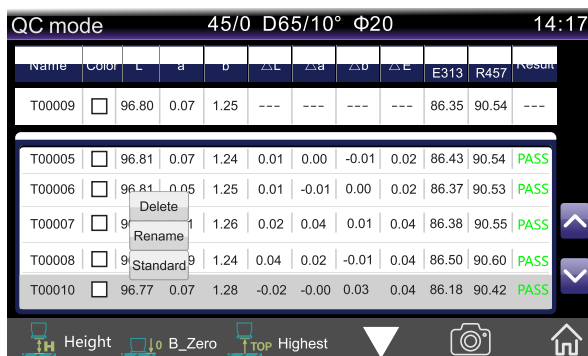

Figure 42 Use  $\Delta E^*$  to Calculate Color Difference

### 3.6.2 Set Optional Chromaticity Index

In the color index interface, click the "Optional Chromaticity Index" radio column to enter the optional chromaticity index selection interface.

Click on a color index to select the corresponding color index. The color index is optional. If you want to cancel the selection, click the selected color formula again. After selecting the color index, click "✓" to confirm.

Click to select the color index, and the green display represents selected. Click the selected color index again to cancel the selection.

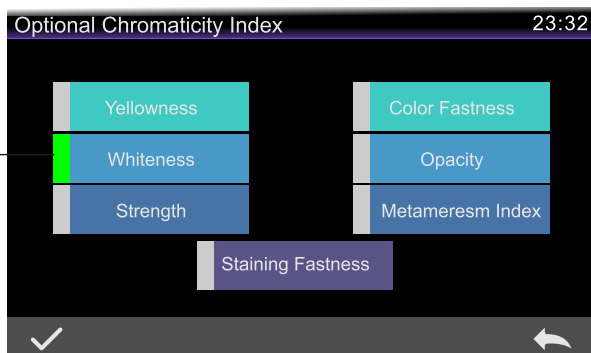

Figure 43 Select the Whiteness Index Interface

The selected color index will be displayed in the color index display area of the standard and sample test (depending on the index, it may only be displayed in the sample), as shown in Figure 44 for the whiteness display interface.

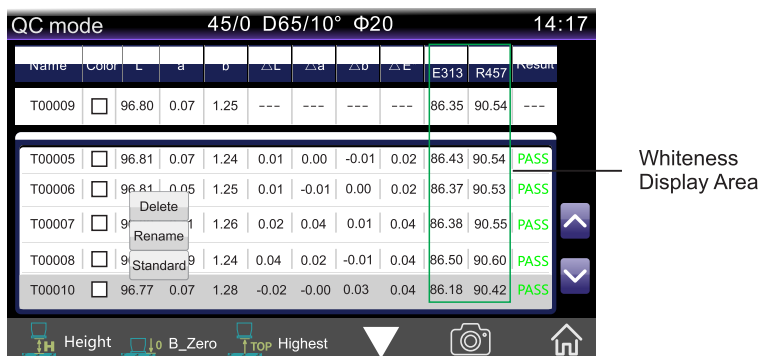

Figure 44 The Whiteness Index Interface Under the Sample Measurement Interface

### 3.6.3 Parameter Factor Settings

Click "Parameter Factor Settings" under the color index interface to enter the parameter factor settings interface, as shown in Figure 45

#### 1) Set Parameter Factor

For the color difference formulas CIE DE2000 ( $\Delta E_{00}$ ), CIE DE1994 ( $\Delta E_{94}$ ), CMC ( $\Delta E_{cmc}(l:c)$ ), the user can set the parameter factors of L, C, H (CMC can only set L and C). The following takes the parameter factor setting of  $\Delta E_{94}$  as an example: click "ΔE94 factor" to enter the  $\Delta E_{94}$  factor setting interface (as shown in Figure 46).

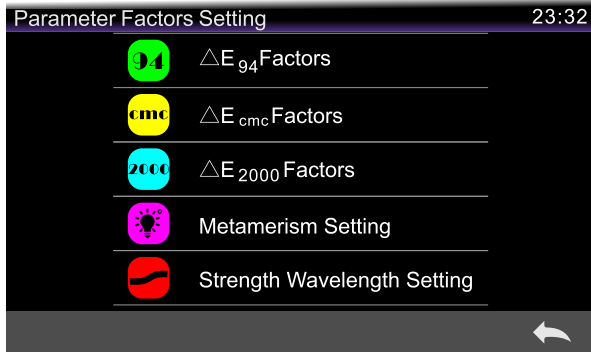

Figure 45 Parameter Factor Settings Interface



Figure 46 ΔE94 Factor Setting Interface

Click the values of factor KL, factor KC, and factor KH to enter the editing interface (as shown in Figure 47), and then enter the new value, click " ✓ " to confirm, and click " ← " to cancel the saving settings.

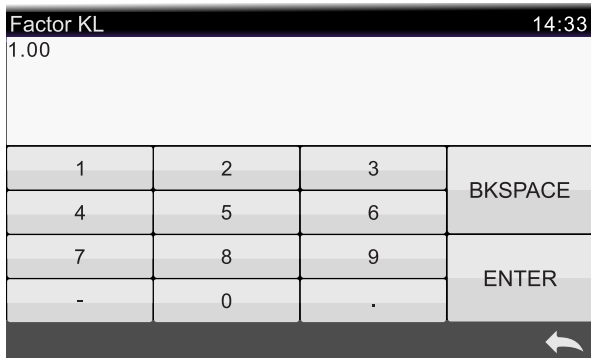

Figure 47 The Editing Interface of Factor KL

## 2) Metamerism Settings

In the parameter factor settings interface, click "Metamerism Settings" to enter the metamerism settings interface, as shown in Figure 48, set the reference light source 1 and the light source 2 to be measured respectively, after the setting is completed, click "✓" to confirm, and click "←" to cancel saving settings.

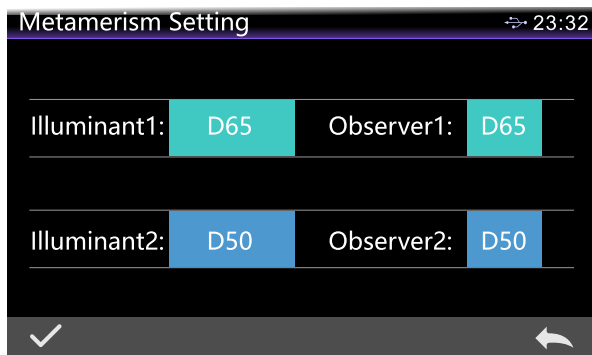

Figure 48 Metamerism Settings Interface

## 3.7 Tolerance Setting

Click "Tolerance Setting" on the main menu interface to enter the tolerance setting interface, as shown in Figure 49. In this interface, you can edit the color difference formula or the tolerance range corresponding to the color space. Regardless of the color difference formula or color space selected, it can be used as a basis for discrimination. When the color difference formula  $\Delta E^*$  and the color space CIE LAB are selected, the upper and lower ranges of  $\Delta L^*$ ,  $\Delta a^*$ , and  $\Delta b^*$  of this color space can be set, and it can be validated or invalidated, as shown in Figure 50, if the measured value exceeds this range, it is judged as fail.

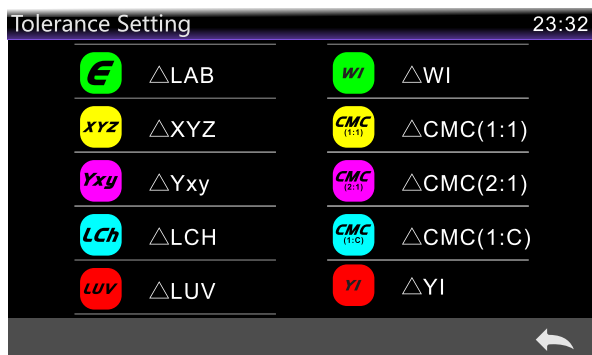

Figure 49 Tolerance Setting Interface

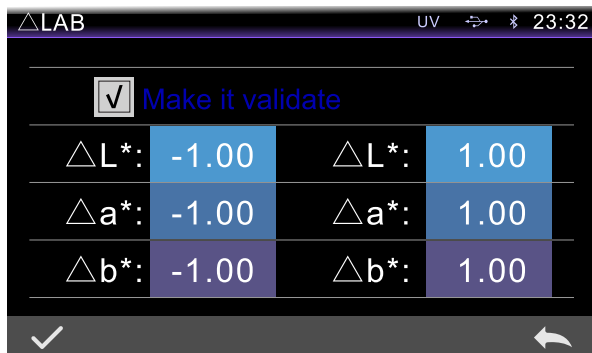

Figure 50 ΔLab Tolerance Editing Interface

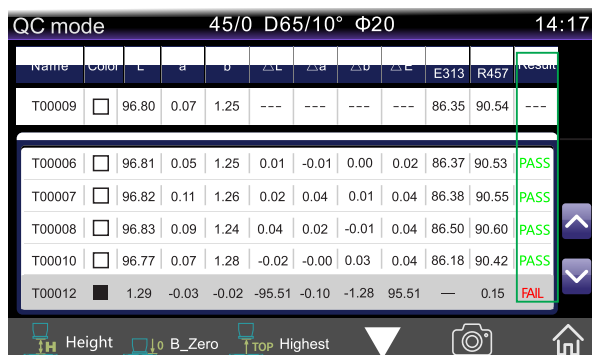

Figure 51 Select the Test Result Prompt of the ΔE Color Difference Formula

### 3.8 System Settings

Click "System Settings" in the main menu to enter the system settings interface, as shown in Figure 52, Figure 53, and Figure 54.

System settings include Bluetooth, buzzer, measurement mode, calibration validity period, measurement control methods, language, time, screen backlight time, screen backlight brightness, etc., as well as rest and view instrument version information.

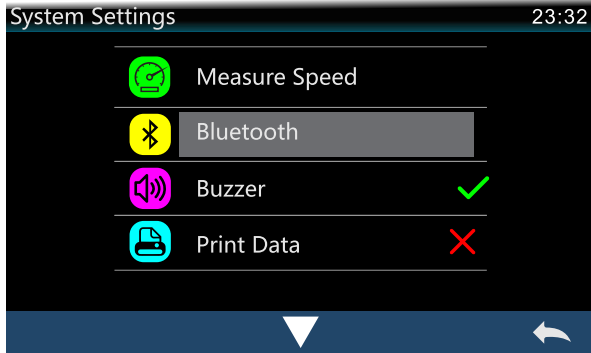

Figure 52 System Settings Interface

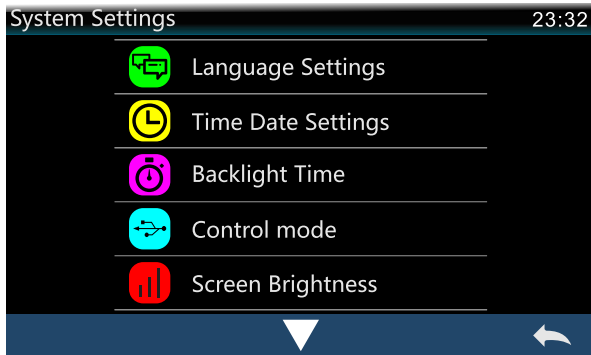

Figure 53 System Settings Interface

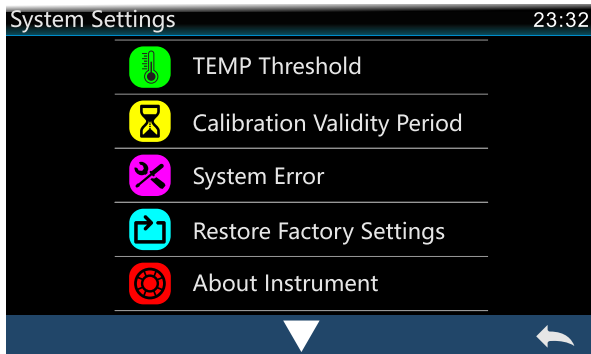

Figure 54 System Settings Interface

## 3.8.1 Measure Speed

Click "Measure Speed" in the system settings interface to enter the measuring speed setting interface, as shown in Figure 55. The user can select the speed of sample measurement by clicking "Very Fast", "Fast", and "Standard" according to their needs. Selecting "Very Fast" corresponds to a measurement speed of 100%; selecting "Fast" corresponds to a measurement speed of 50%, and selecting "Standard" corresponds to a measurement speed of 0%. The faster the measurement speed, the stability will decrease slightly, and the user can adjust the measurement speed according to the actual measurement conditions. It is also possible to precisely adjust the measurement speed by clicking "+" and "-" at a rate of 10% each time. After setting, click the confirm " ✓ " below to save the settings, and click the return " ← " button to cancel saving.

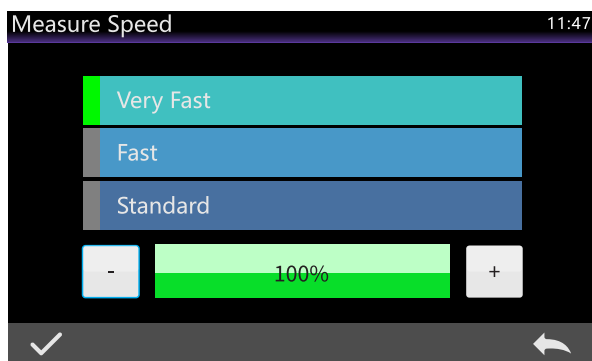

Figure 55 Measure Speed Setting

## 3.8.2 Bluetooth

For instruments equipped with Bluetooth (some instruments have not yet opened this function), you can communicate with PC color management software through Bluetooth. For the operation method of Bluetooth and PC software communication, please refer to section 2.5.2.

## 3.8.3 Buzzer

The buzzer switch controls whether or not a beep will sound during measurement. When the buzzer is turned on, a reminder sound will sound at the end of each measurement; otherwise, there will be no reminder sound during measurement.

## 3.8.4 Print Data

Turn on the print data switch in the system settings and connect to the printer to print data. For specific operations, see chapter 2.6.

## 3.8.5 Language Settings

Language settings is used to set the language of the instrument interface. In the system settings interface, click "Language Settings", and then select the corresponding language to confirm.

### 3.8.6 Time and Date settings

When the instrument leaves the factory, it is usually synchronized with the manufacturer's local time, and the customer can also set the time of the instrument according to the actual situation. Click "Time and Date Settings" in the system settings interface to enter the time and date settings interface.

**Date Setting:** Click "Date Setting" to view the date and month, click on a date to set the date, as shown in Figure 56. After inputting, click confirm " ✓ " below to save the set date, and click the return " ⬅ " button to cancel saving.

**Time Setting:** Click the check box under "Time Setting", and a drop-down box will pop up. Set the time one by one according to your needs, that is, hour and minute, as shown in Figure 57. After inputting, click the confirm " ✓ " below to save the set time, and click the return " ⬅ " button to cancel saving.

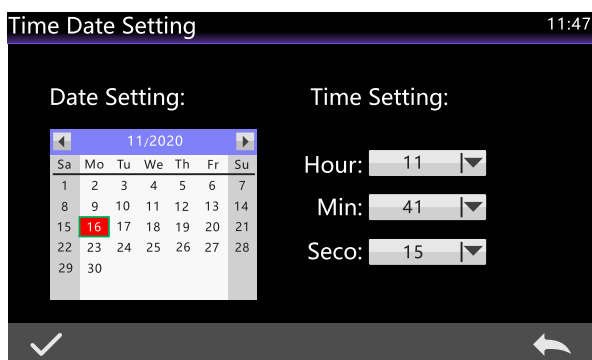

Figure 56 Date Setting Interface

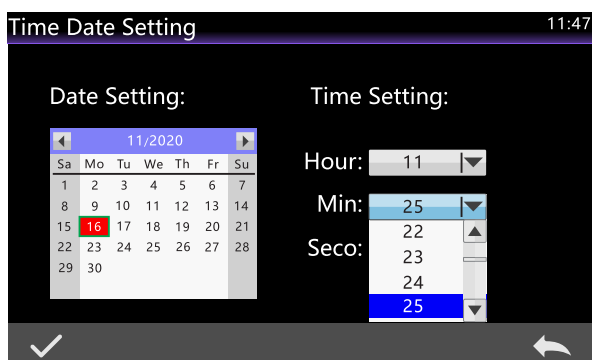

Figure 57 Time Setting Interface

## 3.8.7 Backlight Time

Click "Backlight Time" in the system settings interface to enter the "Backlight Time" selection interface.

The backlight time include: "1 Minute", "5 Minutes", "10 Minutes", "30 Minutes" and "Normally on". If normally on is selected, the screen will not automatically stay off when there is no operation, and will not automatically shut down. If it is set to "1 minute", the instrument will count from the last customer operation, and will enter the backlight state after 1 minute. After 3 minutes, the instrument will automatically soft shut down and enter the power saving mode. The meanings of "5 minutes", "10 minutes" and "30 minutes" are the same as above. As shown in Figure 58.

The instrument can be turned on by short pressing the measurement button during the backlight time; when the instrument is softly shut down, the instrument can be awakened by long pressing the measurement button. Please refer to section 2.1 for the specific power on/off content. The default screen backlight time of the instrument is "5 minutes", making it in power saving mode.

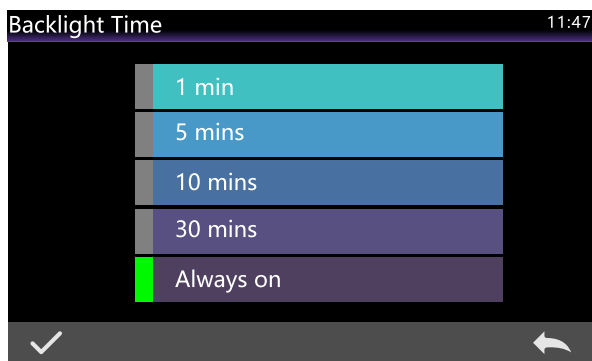

Figure 58 Backlight Time

## 3.8.8 Measurement Control Mode

When the instrument communicates with the PC software, the customer can set specific measurement control methods as needed. Click "Measurement Control Methods" in the system settings interface to enter the measurement control methods selection interface (as shown in Figure 59), select the corresponding mode, and then confirm.

**Button:** Select this mode, the instrument measurement can only be triggered by the instrument measurement button to complete the data test, and upload the data to the PC software.

**PC Software:** Select this mode, the instrument measurement can only be triggered by the PC software measurement button to complete the data test, and upload the data to the PC software.

**Button | PC software:** select this mode, the customer can complete the sample test through the instrument measurement button or the PC software measurement button, and upload the data. This mode is the default selection mode of the instrument.

**Note:** The measurement control mode only takes effect when the instrument is connected to the PC software. When it is not connected, you can only use the measurement button to measure.

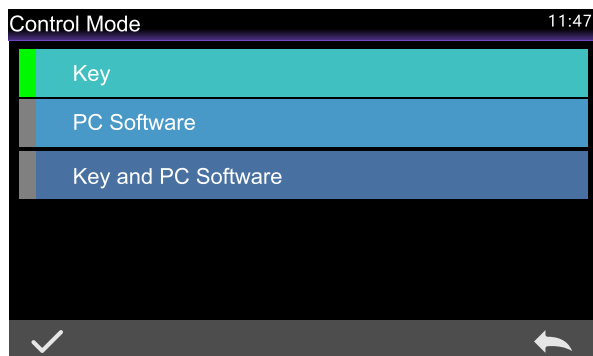

Figure 59 Measurement Control Mode

### 3.8.9 Screen Brightness

Click "Screen Brightness" in the system settings interface to enter the "Screen Brightness" interface, as shown in Figure 60.

Click "+" to increase the screen brightness, and click "-" to decrease the screen brightness. It can be adjusted according to the actual working conditions. After the adjustment is completed, click the confirm " ✓ " below to save the set time, and click the return " ← " button to cancel the saving.

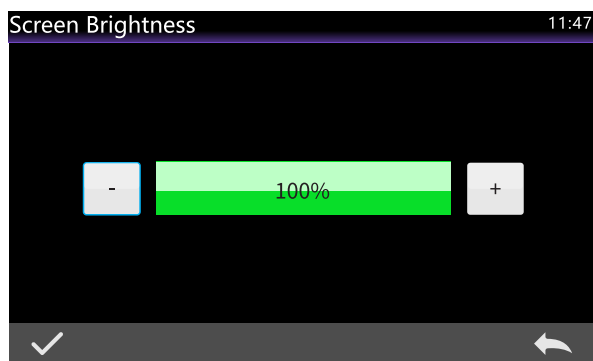

Figure 60 Screen Brightness Adjustment Interface

### 3.8.10 Temperature Threshold

During black and white calibration, the temperature sensor will automatically collect the current ambient temperature. Click "Temperature Threshold" on the system settings interface to enter the "Temperature Threshold" interface. The user can set the upper and lower temperature thresholds as needed, as shown in Figure 61. The setting range of the upper and lower temperature thresholds is 1~9°C. Normally, you can set the upper and lower temperature thresholds to 5°C. After the setting is completed, click OK " ✓ " to save the settings, and click Return " ← " to cancel.

When the ambient temperature exceeds or falls below the temperature threshold (the ambient temperature collected during black-and-white calibration + the upper and lower temperature thresholds set), the instrument reminds the need to perform black-and-white calibration again, and re-collect the current ambient temperature.

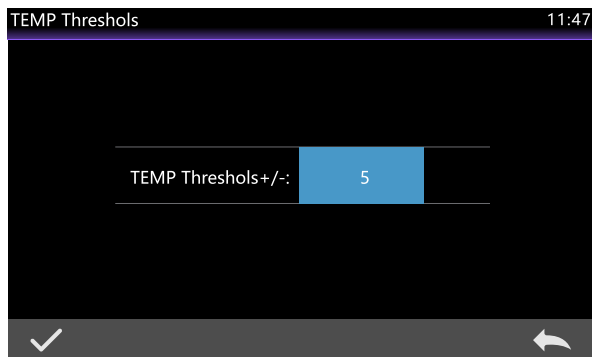

Figure 61 Upper and Lower Temperature Threshold Setting

### 3.8.11 Calibration Validity Period

Black and white board calibration is used as the benchmark for chromaticity data measurement and must be performed accurately, otherwise it will affect the validity of the test data. When the black and white board calibration environment is quite different from the current sample test environment (such as severe temperature fluctuations), it is necessary to perform the black and white board calibration on the instrument in time. At an interval of 24 hours, it is also recommended to do the black and white board calibration again when testing the samples. The "Calibration Validity Period" of the instrument in the system settings manages the validity period of black and white board calibration.

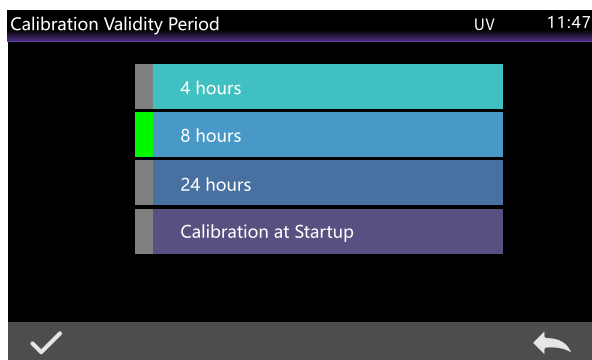

Figure 62 Selection Interface of Calibration Validity Period

Click "Calibration Validity Period" in the system settings interface to enter the calibration validity period selection interface, as shown in Figure 62, which can be 4 hours, 8 hours, or 24 hours, Calibration at Startup.

If you select 4 hours, the instrument's black and white calibration validity period will expire 4 hours after each calibration. If it expires, you will only be able to view the data, but the test cannot be completed. After the black and white board is re-calibrated, the calibration validity period will restart.

If you select 8 hours, the instrument's black and white calibration validity period will expire after 8 hours of each calibration. If it expires, you can only view the data, but the test cannot be completed. After the black and white board is re-calibrated, the calibration validity period will restart.

If you select 24 hours, the instrument's black and white calibration validity period will expire 24 hours after each calibration. If it expires, you will only be able to view the data, but the test cannot be completed. After the black and white board is re-calibrated, the calibration validity period will restart.

If you select Calibration at Startup, the validity period of the black and white calibration of the instrument will expire every time it is turned on. If it expires, you can only view the data, but the test cannot be completed. After the black and white calibration is restarted, the validity period of the calibration restarts.

When the black and white calibration expires, in the measurement interface, press the measurement button will pop up instructions, and can not measure normally. The measurement can be performed only after the correct black and white calibration has been performed again.

### 3.8.12 System Error

Click "System Error" on the system settings interface to enter the "System Error" interface. If the system fails, you can view the system error list.

### 3.8.13 Restore Factory Settings

Click "Restore Factory Settings" in the system settings interface, and you will enter the interface shown in Figure 63. Press " ✓ " to clear all measurement records and customer settings, and restore to the factory state; click the return " ← " button to cancel this operation.

**Note:** This operation will clear all data and user settings and restore to the default state. All data cannot be restored. Please operate with caution.

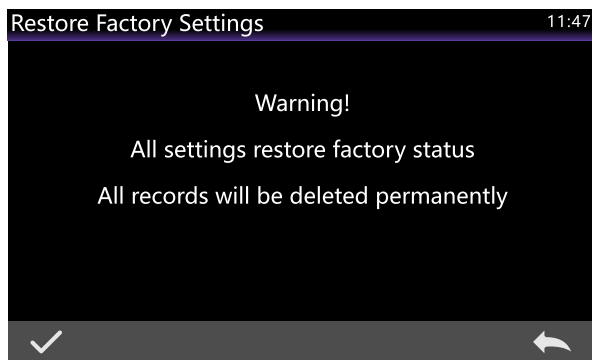

Figure 63 Restore Factory Settings Interface

---

### 3.8.14 About Instrument

Click "About Instrument" in the system settings interface to enter the "About Instrument" interface. You can view the product model, SN code, software version, hardware version, whiteboard number and other information of the instrument.

## 4. Daily Repair and Maintenance of the Instrument

- 1) This instrument is a precision optical instrument. Please keep and use the instrument properly. Avoid using and storing the instrument in a humid, strong electromagnetic interference, strong light, and dusty environment. It is recommended to use and store the instrument in a standard laboratory environment (temperature 20 degrees Celsius, 1 standard atmosphere, humidity 50~70%RH).
- 2) The standard board is a precision optical component, so it should be kept and used properly. Avoid hitting the working surface with sharp objects, and contaminating the working surface with dirt, and avoid exposing the standard board to strong light. Clean the working surface of the standard plate with a wiping cloth dipped in alcohol regularly, and remove the dust on the working surface in time during calibration.
- 3) In order to ensure the validity of the test data, it is recommended that the complete color measuring instrument and the standard board should be inspected by the manufacturer or a qualified metrology institute for one year from the date of purchase.
- 4) This instrument is powered by an external power adapter. Please use the original power adapter. At the same time, the power supply should be used in a standard manner to avoid frequent plugging and unplugging of the power supply to protect the power supply performance and extend the service life of the power supply.
- 5) Please do not disassemble or assemble the instrument privately. If you have any questions, please contact the relevant after-sales staff, tearing off the easy-to-tear label will affect the after-sales maintenance of the instrument.

## 5. Technical Specifications

### 5.1 Features

- 1) Non-contact, movable measuring head, preferably 200 milliseconds acquisition speed, moving up and down according to the actual height of the measured object; standard CIE 45/0 geometric optical structure / CIE D8 (excluding specular reflection light) geometric optical structure optional; Measure the reflectance of objects and various chromaticity values.
- 2) High hardware configuration: 7-inch TFT pure color capacitive touch screen; Bluetooth 5.0; up to more than 25,000 storage capacity.
- 3) High optical resolution, dual optical path, concave blazed grating, 256 pixel CMOS detector.
- 4) Various measuring apertures: conventional aperture  $\Phi 20\text{mm}$ ,  $\Phi 8\text{mm}$ ,  $\Phi 4\text{mm}$  can be customized.
- 5) Temperature monitoring and compensation, built-in temperature sensor to monitor and compensate the test environment to ensure more accurate measurement results.
- 6) Long-life, full-spectrum LED, test wavelength range of 400~700nm.
- 7) USB/Bluetooth dual communication modes, wider adaptability.

- 8) Multiple measurement modes: quality control mode, sample mode, to meet more customer needs.
- 9) Camera locating function.
- 10) PC software has powerful function extensions.
- 11) A variety of communication interfaces, detachable bottom plate, adjustable test speed, specially tailored for automated assembly lines.

## 5.2 Technical Specifications

※ **Different product models, technical specifications, and configurations are different**

<b>Non-Contact Spectrophotometer</b>		
<b>Product Series</b>	<b>45/0 series</b>	<b>D/8 series</b>
Optical Geometry	Comply With Standard CIE NO. 15, GB/T 3978, GB2893, GB/T 18833, IS07724-1, ASTM E1164, DIN5033 TEIL7, GB 2893, GB/T 18833	Comply With Standard CIE NO. 15, GB/T 3978, GB2893, GB/T 18833, IS07724-1, ASTM E1164, DIN5033 TEIL7, GB 2893, GB/T 18833
Lighting Source	Full Spectrum Led Light Source	Full Spectrum Led Light Source, <b>UV Light Source</b>
Spectrophotometric Method	Concave Grating	Concave Grating
Sensor	256 Pixel Dual Array CMOS Image Sensor	256 Pixel Dual Array CMOS Image Sensor
Measurement Wavelength Range	400~700nm, 10nm Output	400~700nm, 10nm Output
Reflectance Measurement Range	0~200%	0~200%
Measuring Aperture	φ20mm(φ8mm Can be Customized)	φ20mm(φ8mm Can be Customized)
Non-Contact Distance	7.5±0.1mm	3.0±0.1mm
Sample Height	0~160mm ( Utilize the Original Support Base)	0~160mm ( Utilize the Original Support Base)
Distance Adjustment Methods	Manual Adjustment(Test Height Can be Stored)	Manual Adjustment, <b>Automatic Adjustment</b> (Test Height Can be Stored)
Measurement Modes	Sample Mode Quality Control Mode Continuous Statistics Mode	Sample Mode Quality Control Mode Continuous Statistics Mode
Color Space	CIE LAB,XYZ,Yxy,LCh,CIE LUV,Musell,s-RGB,HunterLab,βxy,DIN Lab99	CIE LAB,XYZ,Yxy,LCh,CIE LUV,Musell,s-RGB,HunterLab,βxy,DIN Lab99
Color Difference Formula	$\Delta E^*ab, \Delta E^*94, \Delta E^*cmc(2:1), \Delta E^*cmc(1:1), \Delta E^*00, \Delta E(Hunter), DIN \Delta E99$	$\Delta E^*ab, \Delta E^*94, \Delta E^*cmc(2:1), \Delta E^*cmc(1:1), \Delta E^*00, \Delta E(Hunter), DIN \Delta E99$
Other Chromaticity Indexes	WI(ASTM E313, CIE/ISO,AATCC,Hunter), YI(ASTM D1925, ASTM 313), Metamerism Index MI, Staining Fastness, Color Fastness, Strength, Opacity	WI(ASTM E313, CIE/ISO,AATCC,Hunter), YI(ASTM D1925, ASTM 313), Metamerism Index MI, Staining Fastness, Color Fastness, Strength, Opacity
Observer Angle	2°/10°	2°/10°

## Non-contact Spectrophotometer User Manual

Observation Light Source	D65,A,C,D50,D55,D75,F1,F2(CWF),F3,F4,F5,F6,F7(DLF),F8,F9,F10(TPL5),F11(TL84),F12(TL83/U30)	D65,A,C,D50,D55,D75,F1,F2(CWF),F3,F4,F5,F6,F7(DLF),F8,F9,F10(TPL5),F11(TL84),F12(TL83/U30)
Display	Spectral Graph/Data, Sample Chromaticity Value, Color Difference Value/Graph, Chromaticity Graph, Color Simulation, Pass/Fail Result, Display Tolerance Setting	Spectral Graph/Data, Sample Chromaticity Value, Color Difference Value/Graph, Chromaticity Graph, Color Simulation, Pass/Fail Result, Display Tolerance Setting
Measure Time	Fast Mode About 1.5s (Adjustable)	Fast Mode About 1.5s (Adjustable)
Data Storage	Sample Mode + Quality Control Mode 18,000 Continuous Statistics Mode 30,000, Totaling no More Than 48,000	Sample Mode + Quality Control Mode 18,000 Continuous Statistics Mode 30,000, Totaling no More Than 48,000
Repeatability	Spectral Reflectance: Within 0.08% Standard Deviation Chromaticity Value: Within $\Delta E^*ab$ 0.04 (After warming up, the average value of 30 measurements on the whiteboard at an interval of 5s)	Spectral Reflectance: Within 0.08% Standard Deviation Chromaticity Value: Within $\Delta E^*ab$ 0.04 (After warming up, the average value of 30 measurements on the whiteboard at an interval of 5s)
Inter-Instrument Error	$\Delta E^*ab$ Within 0.25 (Average value of 12 color tiles of bcra series II)	$\Delta E^*ab$ Within 0.25 (Average value of 12 color tiles of bcra series II)
Measurement Methods	Single Measurement, Average Measurement (2~99 Times)	Single Measurement, Average Measurement (2~99 Times)
Locating Method	Camera Locating	Camera Locating
Size	330*250*370mm	330*250*370mm
Weight	About 10Kg	About 10Kg
Power Supply	Dc 24V, 3A Power Adapter	Dc 24V, 3A Power Adapter
Lighting Source Life	More Than 3 Million Measurements in 5 Years	More Than 3 Million Measurements in 5 Years
Display Screen	TFT True Color 7inch, Capacitive Touch Screen	TFT True Color 7inch, Capacitive Touch Screen
Port	USB, Bluetooth® (Some models don't have)	USB, Bluetooth® (Some models don't have)
Language	Simplified Chinese, Traditional Chinese, English	Simplified Chinese, Traditional Chinese, English
Operating Temperature Range	0~40°C, 0~85%Rh (No Condensation), Altitude: Less Than 2000m	0~40°C, 0~85%Rh (No Condensation), Altitude: Less Than 2000m
Storage Temperature Range	-20~50°C, 0~85%Rh (No Condensation)	-20~50°C, 0~85%Rh (No Condensation)
Standard Accessories	Power Adapter, Manual, Data Cable, Standard Calibration Whiteboard, Black Calibration Trap	Power Adapter, Manual, Data Cable, Standard Calibration Whiteboard, Black Calibration Trap

If the product upgrade causes the parameters to change, please refer to the data published on the official website.

## Appendix

### 1.Object Color

There are three elements to observing color: lighting source, object, and observer. Changes in any of these three will affect the color perception of the observer. When the lighting source and the observer do not change, then the object will determine the color perception formed by the observer.

The reason why an object can affect the final color perception is that the reflection spectrum (transmission spectrum) of the object modifies the light source spectrum. Different objects have different reflection spectra (transmission spectrum). (Spectrum) modulation to obtain different results, because the observer does not change, so it presents different colors, the principle is shown in the figure below.

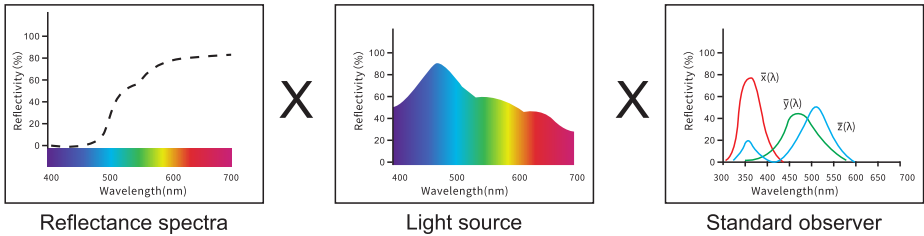

$$= \begin{matrix} L=70.95 \\ a=69.72 \\ b=40.35 \end{matrix}$$

$\Delta L+$  represent whitish,  $\Delta L-$  represent blackish  
 $\Delta a+$  represent reddish,  $\Delta a-$  represent greenish  
 $\Delta b+$  represent yellowish,  $\Delta b-$  represent bluish

### 2.Color Difference Formula

CIE 1976  $\Delta E^*_{ab}$

$$\Delta E^*_{ab} = [(\Delta L^*)^2 + (\Delta a^*)^2 + (\Delta b^*)^2]^{1/2}$$

$$\begin{aligned} \Delta L^* &= L^*_1 - L^*_0 \\ \Delta a^* &= a^*_1 - a^*_0 \\ \Delta b^* &= b^*_1 - b^*_0 \end{aligned}$$

**CIE 2000  $\Delta E^*_{00}$**

$$\Delta E_{00} = \left[ \left( \frac{\Delta L'}{K_L S_L} \right)^2 + \left( \frac{\Delta C'}{K_C S_C} \right)^2 + \left( \frac{\Delta H'}{K_H S_H} \right)^2 + R_T \left( \frac{\Delta C'}{K_C S_C} \right) \left( \frac{\Delta H'}{K_H S_H} \right) \right]^{1/2}$$

$$L' = L^*$$

$$a' = a^* (1+G)$$

$$b' = b^*$$

$$G = 0.5 \left( 1 - \sqrt{\frac{\bar{C}_{ab}^{*7}}{\bar{C}_{ab}^{*7} + 25^7}} \right)$$

**CIE 1994  $\Delta E^*_{94}$**

$$\Delta E^*_{94} = \left[ \left( \frac{\Delta L^*}{K_L S_L} \right)^2 + \left( \frac{\Delta C^*_{ab}}{K_C S_C} \right)^2 + \left( \frac{\Delta H^*_{ab}}{K_H S_H} \right)^2 \right]^{1/2}$$

$$S_L = 1$$

$$S_C = 1 + 0.045 C^*_{ab}$$

$$S_H = 1 + 0.015 C^*_{ab}$$

### 3. Normal color difference allowable range

The allowable range of normal color difference varies depending on different industries and application scenarios. The following are the allowable ranges of color difference for some major industries

Overview:

1. Electronic device industry

Standard:  $\Delta E$  (color difference unit) is usually required to be less than 0.5 to ensure color accuracy in screen display, product appearance, and other aspects.

## 2. Plastic coating industry

Standard: Require  $\Delta E$  to be less than 1.0, applicable to color control of plastic products and coating products.

## 3. Textile industry

General standard:  $\Delta E$  below 2.0 is considered an acceptable range, especially in textile color management.

Specific standards: In some standards, it is required that the color difference of specific parts should not be less than level 4, which is equivalent to a color difference value between 0 and 2.0

## 4. Printing industry

Range: A color cast range between 1.5 and 3.0 is usually considered normal, but specific values may vary depending on product grade and customer requirements. Seeking to be different.

Standard: Some standards stipulate that the color difference value for both fine and general products should not exceed 6.

## 5. Railway signal flag

Standard: The color difference is less than or equal to 3.0 to ensure the clarity and recognition of the signal flag.

### Color difference and perception

$\Delta E$	Perception
0-0.25	Very small or no color difference, ideal match
0.25-0.5	Minor color difference, usually acceptable
0.5-1.0	Minor to moderate color difference, certain applications Acceptable
1.0-2.0	Moderate color difference, perceptible to the human eye, Acceptable in specific applications
2.0-4.0	Obvious color difference, acceptable under specific conditions
> 4.0	The color difference is very large, most applications unacceptable



2.004.01.0130